

RULEBOOK 2026

PNWIC

Pacific Northwest Invitational Championship



OHSET

WAHSET

Revised: 12/4/2024

REVISIONS

12/4/2024 – Updates and Revisions

- Revised Drill Pages 44-47. Removed specific point deduction amounts. Instead of getting point deductions from rulebook, judges should use the points as noted on the Freestyle Drill Score Sheet.
- Revised Cattle events to include the verbiage regarding no backup timers used. If electric eyes fail without interference, a re-ride will be granted.
- Team penning -- Rules to be determined if used
- No chalk line noted for IHOR
- 2 Barrel Flag – any flag carried across the finish line is a NT

This is the rulebook for the Pacific North West Invitational Championship - PNWIC. When a situation is not covered in this book refer to the USEF rule book.

Table of Contents

Contents

Table of Contents	4
Junior Horse.....	5
Athlete Uniform	5
Disqualifications	5
CATTLE EVENTS.....	7
Breakaway Roping	7
Steer Daubing	9
Two Man Team Sorting.....	11
PERFORMANCE EVENTS	13
Dressage	13
Driving.....	14
Hunt Seat Equitation	15
Hunt Seat Equitation Over Fences	16
In Hand Obstacle Relay	18
Trail.....	20
In Hand Trail	21
Reining.....	22
Saddle Seat	24
Showmanship	25
Western Horsemanship/Stock Seat Equitation	26
Working Pairs.....	27
Working Rancher	29
Team Versatility	30
TIMED EVENTS	35
Barrels	39
Idaho Figure 8.....	40
Keyhole.....	40
Pole Bending.....	41
Drill Events	44
Freestyle Program (5 or more)	45
Freestyle Working Fours	45
Drill Team Judging Guidelines.....	45
Drill Design.....	45
General Impression.....	46

PNWIC POLICIES

Junior Horse

1. Junior horse is 5 years of age and under
2. For competition purposes, any equine is considered one year old the first day of January following the actual date of foaling. January 1st will be considered the birth date for considering age from then on.

Athlete Uniform

1. Athletes with long hair need to wear it neatly so that the athlete's number is clearly visible.
2. Helmets
 - a. All athletes **MUST** wear an ASTM/SEI helmet, properly adjusted according to manufacturer's instructions while mounted or in a vehicle (cart, wagon, buggy, etc.) being pulled by one or more equines..
 - i. The helmet must maintain the proper adjustment throughout the entire event. At the judge's discretion, if the helmet is not fitted properly, the infraction may result in a disqualification
 - ii. Manufacturer installed elements such as rhinestones are allowed.
3. Polo Shirt
 - a. Upon entering the arena for an event, the athlete must wear a solid colored, long sleeve polo shirt with collar, and long sleeves rolled down and shirt tucked in as part of the required uniform.
 - b. Uniform should be clean and in good repair (no rips, tears or holes)
 - c. Sponsor logos are permitted according to each state's rules.
 - d. Athletes may wear a garment under the polo, but it may not cover any part of the polo, this includes the collar.
4. Pants
 - a. Solid color western style pants or jeans OR English breeches/jodhpurs.
 - i. Saddle seat pants may have pinstripes
 - b. Pants must be worn on the outside of boots for performance classes.
 - c. Pants may be tucked into boots in Daubing, Break Away Roping, Sorting, Team Penning and timed events.
5. Boots
 - a. Appropriately corresponding boots for the style of riding and tack used.
 - i. Boots must have a definite heel - no ramps are allowed.

Disqualifications

1. List of reasons for disqualification:
 - a. Uniform shirt untucked.
 - b. Uniform shirt sleeves rolled up.
 - c. Cruelty to animals.
 - d. Bad language.

- e. Helmet not adjusted properly, which may include straightening helmet while on course. "On course", is further clarified as "after first crossing the start/finish line and before crossing that line again.
- f. Use of prohibited equipment as defined in the Class Rules section of this manual.
- g. Discourtesy, direct abuse or threatening conduct towards an approved judge, volunteer or committee member.
- h. If an athlete enters the arena with missing required equipment, illegal equipment, or illegal use of permitted equipment, including uniform violation, not considered to be unsafe, the athlete will be allowed to continue the course and receive scores and comments, but will be disqualified from the event.
- i. Obvious lameness or unsoundness detected in participation equine will result in disqualification.

CATTLE EVENTS

Breakaway Roping

1. Any encouragement of forward motion or holding back by anyone other than the rider will be a disqualification or no time. A coach, advisor or athlete may bring the equine into the arena or into the box, but is prohibited to hold the equine, or encourage forward motion.
2. Cattle draw will be a chute draw for this event, including reruns.
3. This is a timed event with a 30 second time limit with 2 goes per rider.
4. Cattle with horns 2" or longer may be caught with a legal head catch. A legal head catch is both horns, a half head or around the neck.
5. Two loops will be permitted. Athlete may rebuild or carry the second loop.
6. When a mixed herd of polled cattle and cattle with less than 2" horns are used, a legal catch is to be any loop that goes completely over the calf's head and draws up on any part of the calf's body causing the rope to break away from the saddle horn. A legal horned catch will be: both horns, half a head or catch as described in the previous sentence.
7. One or two ropes are to be tied to the saddle horn by a heavy string, 90lb test, in such a manner as to allow the rope to be released from the horn when the cow reaches the end of the rope.
8. A visible cloth or flag must be attached to the end of the rope tied to the horn to make it easier for the flagger to see it break free.
9. The contestant shall be awarded a "no time" should he/she break the rope from the horn by hand or touch the rope or string after the catch is made or if the rope dallies around the horse and/or does not break free when the cow reaches the end of the rope.
10. Time will start with the electronic timer and stopped as indicated by the judge dropping the flag or wireless hand switch timer when the rope string breaks from the saddle horn. No backup timers used, if electric eyes fail without interference, a re-ride will be granted
11. Horse must be facing out/forward before calling for the steer's release.
12. For facilities that do not have permanent boxes and chutes in place, the boxes will be 12 feet wide, and from the front of the chute to the back of the box will be no less than 12 feet and no more than 14 feet. For the depth of the box, measure from the pivot point of the head gate back 12 to 14 feet. For the width, measure over 12 feet. For facilities where permanent boxes and chutes are in place, the existing boxes may be used as-is provided that the dimensions of the boxes are no smaller than 12 feet wide by 12 feet deep.
13. Electronic eye is the only barrier option
14. The cow must break the 6 foot barrier for the athlete to leave the box.
 - a. A ten second penalty for breaking the barrier will be added
 - b. If a re-ride is issued and the barrier is broken on the initial run, the 10 second penalty will carry over to the re-ride.
15. Any attempt by a contestant to position his/her equine in the box enabling him/her to rope the calf without leaving the box shall be a "no-time".
16. An athlete must request a re-ride prior to throwing the rope and/or any attempt is made

- to catch the steer. Must make the request prior to the next rider entering the box.
17. Cattle handler shall be consistent throughout the event.
 18. The judge will determine legal catches or any other rule infraction, the judge's decision is final.
 - a. One judge will be mounted.
 - b. All contestants will remain mounted while in the arena.
 - c. Fall of rider or rider dismounted, athlete will be awarded a "no time"
 - d. Roughing cattle, as determined by judge, athlete will be awarded a "no time"
 - e. Judges will eliminate any athlete and/or animal they consider to be unsafe
 19. Two judges are needed for this event. The flagger (horseback) judge will raise their flag to signal the area is ready for the next athlete and also inspect the cattle, eliminating any that they find objectionable. During the event, the flagger judge will determine legal catches/dubs and/or any rule infractions. The line judge will position themselves at the cattle barrier line and will signal the announcer to call for the next competitor. The line judge will keep time for the athlete entering the box (60 seconds with a 15 second warning). The line judge will also check the string (in breakaway roping) before entering the box to ensure it is secure to the horn. Both the flagger and the line judge will monitor the athlete to ensure no rule violations while in the "box"
 20. An athlete will receive 60 seconds from the time their name is called to the time the chute opens. If athlete is not in the box and ready when that period of time is up then they will be awarded a "no time".
 - a. Announcer will not call athlete's name until signaled by the judge.
 - b. The line judge or announcer may keep the time.
 - c. The announcer will call the 30 second warning for the athlete getting into the box.
 - d. The Line Judge will call for a 15 second warning
 21. If there is a timer foul while attempting to enter the box, elapsed time will be carried over once course is reset
 22. Placing: All riders with successful catches in 2 goes beat any riders with only 1 go with successful catch. Placing will be determined first by the number of successful catches, then lowest total time.
 23. The haze line will be aligned to the left of the header's box when looking out of the box. The judges determine the exact position of the haze line based on safety considerations for the arena in use.
 24. Athletes enter and compete from the heeler box.
 25. Required Equipment:
 - a. Bridle or hackamore
 - b. Western style saddle with horn
 - c. Roping, Romal or mecate reins
 - d. Rope
 - e. Breast collar recommended
 26. Optional Equipment, including but not limited to:
 - a. Throatlatch
 - b. Slip or gag bits
 - c. Hackamore (including mechanical)
 - d. Tie-downs attached to/or under breast collar
 - e. Protective boots, leg wraps and bandages

- f. Nosebands
 - g. Martingales , fitted properly as not to propose a danger if horse falls or athlete loses control (to be decided by judge)
 - h. Western spurs
 - i. Chinks
27. Prohibited:
- a. Roughing cattle
 - b. Rope may not pass through bridle, tie down, neck rope or any other device
 - c. Halters
 - d. Split reins even if tied or joined together
 - e. Bits or equipment that judge may consider severe
 - f. Chaps & half chaps

Steer Daubing

1. Any encouragement of forward motion or holding back by anyone other than the rider will be a disqualification. A coach, advisor or athlete may bring the equine in the arena or into the box, but it is prohibited to hold the equine, or encourage forward motion.
2. Cattle draw will be a chute draw for this event, including reruns.
3. Equipment for arena:
 - a. 4' dauber with a tennis ball at the end dipped in a "bright" paste of contrasting color
 - b. Mustard is not permitted.
4. This is a timed event with a 15 second limit with 2 goes.
 - a. Time starts when a cow breaks the barrier.
 - b. No backup timers used, if electric eyes fail without interference, a re-ride will be granted
 - c. Horse must be facing out/forward before calling for the steer's release. Time stops when the judge drops his/her flag or wireless hand switch timer. Athlete must raise the 4' dauber above his head to indicate a successful daub. A successful daub is placed between the withers and tail of the cow.
 - d. If time is called by athlete and mark is not visible on the steer a "no time" will be awarded.
 - e. If the dauber is thrown at steer or dropped by athlete a "no time" will be awarded.
5. For facilities that do not have permanent boxes and chutes in place, the boxes will be 12 feet wide, and from the front of the chute to the back of the box will be no less than 12 feet and no more than 14 feet. For the depth of the box, measure from the pivot point of the head gate back 12 to 14 feet. For the width, measure over 12 feet. For facilities where permanent boxes and chutes are in place, the existing boxes may be used as-is provided that the dimensions of the boxes are no smaller than 12 feet wide by 12 feet deep.
6. An athlete must request a re-ride prior to daubing the steer and/or any attempt is made to daub the steer. Must make a request prior to the next rider entering the box.
7. The cow must break the 6-foot barrier for the athlete to leave the box.
 - a. A ten second penalty for breaking the barrier will be added to time.
 - b. If a re-ride is issued and the barrier is broken on the initial run, the 10 second penalty will carry over to the re-ride.

8. Cattle handler shall be consistent throughout the event. Any attempt by a contestant to position his equine in the box enabling him/her to daub the steer without leaving the box shall be a no-time.
9. Dropping the daubing stick will result in a "no time".
10. The judge will determine legal daubs or any other rule infraction, the judge's decision is final.
 - a. One judge will be mounted.
 - b. All contestants will remain mounted while in the arena.
 - c. Fall of rider or rider dismounting will be awarded a "no time"
 - d. Roughing cattle, as determined by judge, athlete will be awarded a "no time"
 - e. Judges will eliminate any athlete and/or animal they consider to be unsafe
11. Only one judge will be needed, on horseback watching for infractions regarding the horse in the box, and watching for a legal daub.
12. An athlete will receive 60 seconds from the time their name is called to the time the chute opens. If athlete is not in box and ready when that period of time is up then they shall be awarded a "no time".
 - a. Announcer will not call athletes name until signaled by the judge.
 - b. Line judge calls time
 - c. Line judge will call for a 15 second warning to athlete in the box
 - d. If there is a timer foul while attempting to enter the box, elapsed time will be carried over once course is reset.
13. All riders running 2 goes with successful daubs beat any rider with only 1 go with successful daub. Placing will be determined first by the number of goes with successful daube, then lowest total time
14. Athletes may come out of either side of the box (header or heeler). Electric eye will be used at PNWIC
15. The haze line will be aligned to the left of the header's box when looking out of the box. The judges determine the exact position of the haze line based on safety considerations for the arena in use.
16. Required Equipment:
 - a. Bridle or hackamore
 - b. Western type saddle with horn
 - c. Roping, Romal or mecate reins
 - d. Breast collar recommended
17. Optional equipment, including but not limited to:
 - a. Throatlatch
 - b. Slip or gag bits
 - c. Hackamore (including mechanical)
 - d. Tie downs attached to/or under a breast collar
 - e. Protective boots, leg wraps and bandages
 - f. Nosebands
 - g. Martingales, fitted properly as to not propose a danger if horse falls or athlete loses control (to be decided by judge)
 - h. Western spurs
 - i. Chinks

18. Prohibited:

- a. Roughing cattle
- b. Rope may not pass through bridle, tie down, neck rope or any other device
- c. Halters
- d. Split reins even if tied or joined together
- e. Bits or equipment that judge may consider severe
- f. Chaps & half chaps

Two Man Team Sorting

1. A team shall be defined as 2 members.
2. Time limit: 60 seconds.
3. No backup timers used, if electric eyes fail without interference, a re-ride will be granted
4. Settling of herds: there will be ten cattle in the arena with visible 0-9 numbers. Fresh herds will be settled for 3 minutes bunched on one side, rolled two or three times (depending on cattle) through the gate single file as best as can be done, not one cow at a time. Cattle will be grouped after each run in the middle or corner of the arena to the judge's satisfaction. Direction of cattle sorted will be determined by the arena chair and/or cattle judge prior to the start of the first go. (Example: every team can sort from the same side.) The judge and/or cow settler may use a competitor's horse which is not entered in the Team Sorting event.
5. Start: starting number for each team will be drawn when the team is in the arena. Judge will raise the flag when the cattle are ready. First rider will cross the start/foul line within three to four seconds, as soon as the settlers are clear. The judge will drop the flag and the announcer will give the number to start and the team will continue sorting in numerical order (ie: 7-8-9-0). Riders do not have to alternate after each cow is sorted.
6. Cattle sorted: teams are judged on the total number of cattle sorted, and on the time. Total cows sorted in two goes beats cattle sorted in one go for placement in total cattle for the average, regardless of the total number of cows. Reverse the order for the second go, within each sorting group, at the discretion of the district chair.
 - a. A cow is sorted and timed when the complete cow crosses the start/foulline.
 - b. If a cow is sorted out of order, it's a no time or if any part of the no-numbered or wrong number cow breaks the start/foul line the team receives a no time.
 - c. If any part of the cow crosses back over after it has been sorted, then the team receives a no-time.
 - d. Each cow will be timed as it is sorted and the clock will be stopped when the tenth cow completely crosses the line. The tenth cow has to be all the way clean.
 - e. Cattle in sequence may cross side to side as long as the correctly numbered cow is a nose ahead.
 - f. A team must sort one cow to be a legal sort and then has the option of letting time run. Zero cows is a "no time".
 - g. In case of a foul (ie:cow escapes), the team can ask for a re-ride or accept the number of cattle sorted at the time the foul occurred. Time will be based on the last sorted clean cow prior to the foul. In case of mechanical error or foul (ie: the clock not being reset), the team has the option of an immediate re-ride or

continuing with the appropriate time added on to the clock.

7. Commitment to cattle: once committed to cattle by the horse breaking the start/foul line, the team is responsible for the cattle. It is the responsibility of the team, before working the cattle, if, in their opinion, accepted. Cattle will be rotated after each cow's number has been called to begin a run.
8. Area size: 50' to 55' +/- 10%. Both sides are equal in size. Gate or gap 12' to 12'4" range. Minimum of 4' panel on each side of gate or gap.
9. No spotting allowed, no one other than the sorting team members may call out or locate a cow or identify a cow that is next in sequence to be sorted or is a dirty cow. This is to include a sorted cow that is trying to cross back through the gate. If the audience calls out or locates a cow, it may result in elimination of that team and a no-time. If the audience is a competing school, that school team may also be eliminated.
10. A team will be disqualified by the judge for any action he/she feels to be unnecessary roughness to the cattle or unsportsmanlike conduct.
11. Roughing: contact with cattle by hands, hats, rope, bats, Romal or any other equipment is a disqualification. Roughing includes, but is not limited to, running over cattle with horses, stepping on cattle while in pursuit running through the herd in such a manner that cattle are knocked down or off stride, horses consistently biting the cattle, and entering the pen with such force on the cattle causing them to collide with the pen panels. Roughing will be a disqualification.
12. Required Equipment:
 - a. Bridle or hackamore
 - b. Western style saddle with horn
 - c. Split reins, roping, Romal or mecate reins
 - d. Breast collar recommended
13. Optional Equipment, including but not limited to:
 - a. Throatlatch
 - b. Snaffle, slip or gag bits
 - c. Hackamore (including mechanical)
 - d. Tie-downs attached to/or under breast collar
 - e. Protective boots, leg wraps and bandages
 - f. Nosebands
 - g. Martingales , fitted properly as not to propose a danger if horse falls or athlete loses control (to be decided by judge)
 - h. Western spurs
 - i. Over and under (to be inspected by judge)
 - j. Chinks
14. Prohibited:
 - a. Roughing cattle
 - b. Rope may not pass through bridle, tie down, neck rope or any other device
 - c. Halters
 - d. Bits or equipment that judge may consider severe
 - e. Chaps & half chaps
15. Team penning
 - a. Rules to be determined if used

PERFORMANCE EVENTS

Dressage

1. USDF, USEF Chapter "DR"
2. Readers are not allowed.
3. A raised court shall be used.
4. Interrupted elements, "off course" or causes to repeat an element will be scored as per USDF rules.
 - a. The judge shall deduct 2 points for the first occurrence, 4 points for the 2nd occurrence. After the third error, the athlete will be eliminated.
 - b. Errors on the test (judge may choose to ring a bell. Athlete re-rides the test from the point directed by the judge).
 - i. The rider turns the wrong way.
 - ii. Omits a movement.
 - c. Error of the test (may choose to not ring the bell. Rider does not re-ride the movement).
 - i. Rider incorrectly rides a movement such as sitting trot instead of posting, trot instead of canter.
 - ii. Incorrect salute.
 - iii. Use of voice or intentional audio aid.
 1. Deduct 2 points from what otherwise would have been scored.
 2. ON element with co-efficient deduct 1 point
5. Cause for elimination
 - a. Fall of horse or rider
 - b. 3 errors of the test
 - c. Failure to enter the court within 45 seconds of the judge ringing the bell
 - d. Equine stepping all four feet outside of the court during the test
6. Class expectations:
 - a. We are looking for correct leads, balanced gaits and elegant, smooth transitions.
 - b. Using leg aids and quiet hands, while taking advantage of the full extent of the arena and letters, will be noted. Flowing circles, resistance-free bending with flexion while creating a rhythm in the pattern will score higher.
 - c. Impulsion where needed is evident in this pattern, while relaxed posture and horsemanship skills on the part of the athlete should make each element look effortless.
 - d. Bit checks are at the discretion of the judge,
7. Minimum required arena equipment:
 - a. All small arena letters (minimum: A, K, E, H, C, M, B, F)
 - b. Poles, chain or fencing to border the entire area (court).
8. Required Equipment:
 - a. English bridle
 - b. Cavesson, Flash and drop nosebands are allowed.
 - c. Dressage, forward or all purpose saddle
 - d. The only bit permitted is the snaffle bit. All snaffle bits must be smooth. Further definition of a snaffle bit: bit where both reins and headstall attach to one ring on the

bit (with the exception of the hanging cheek snaffle). No edges on the mouthpiece, no chain or curb strap may be used. (See USEF DR 121-2. For specifics.)

9. Optional equipment, including but not limited to:
 - a. Spurs of an English type
 - b. Gloves
 - c. Braiding of mane or mane and tail in hunt style
 - d. ½ chaps
 - e. Spurs made of metal, shank must be curved (pointing down) or straight pointing directly back from the center of spur. If rowels are used, they must be free to rotate.
 - f. Dropped, flash, crescent, crossed and regular nosebands are the usable options. Padded nosebands are permitted.
10. Prohibited Equipment
 - a. Whips or crops
 - b. Draw reins
 - c. Non English type spurs
 - d. Western or side saddles
 - e. Bit converters
 - f. Kimberwick or Gag bit
 - g. Ribbon, glitter and sparkle (exception: residual from working pairs when scheduling does not allow its removal.)
 - h. Martingales
 - i. Protective boots, leg wraps and bandages
 - j. Cut back saddle
 - k. Gaited horses or any equine shall not be shown with chains on the feet.
 - l. Bit guards
 - m. Any bit with an edge or twist in the metal

Driving

1. USEF Chapter "DP", WSH
2. A safety inspection of equipment, by the judge, will be performed prior to the event.
3. Headers
 - a. Headers are required any time the horse is hitched to the driving vehicle except while the competitor is working his/her pattern.
 - b. Headers must be a registered volunteer or athlete.
 - c. Athlete headers must be in team uniform.
4. Guide to gaits (speed rates in order).
 - a. Walk - even balanced 4 beat, free, flat footed.
 - b. Jog trot/Trot - slow smooth.
 - c. Working trot - exerts more energy, deliberate and fast
 - d. Extended trot/strong trot - clear but not excessive increase in pace and lengthening of stride while remaining well balanced.
5. Disqualifications
 - a. Except for minor adjustments, athletes who fail to pass the safety inspection:
 - i. Will not be allowed to make corrections.
 - ii. Will not be allowed on course.

6. Class expectations:
 - a. Higher scores will go to the team that stays closest to the obstacles
 - b. Equipment checks are part of the score
 - c. Grooming and clean gear will be noted and will be considered in the Overall Reinsmanship scoring.
 - d. Two separate courses will be set for this class - one for large horses and the other for small horses. Large horses will compete against large horses and small horses will compete against small horses.
 - i. Scoring for the two courses will be combined into one class score.
 - e. Equine and athlete should remain calm and collected when entering the arena.
 - f. The pivot should be steady continual motion with little or no movement in the pivot wheel.
 - g. Bit checks are at the discretion of the judge.
7. Required Equipment
 - a. Blinders
 - b. On heavier vehicle, thimbles or breeching is required
 - c. Over checks or side checks
 - d. Whip; tip of the whip or lash must reach the shoulder of the equine
8. Optional equipment, including but not limited to:
 - a. Aprons
 - b. Knee rugs
 - c. Gloves
 - d. Snaffle, Liverpool or Buxton, Full Cheek and Half Cheeks
 - e. Breeching (Optional only with lighter vehicles)
 - f. Running martingales
 - g. Twisted bits
9. Prohibited equipment
 - a. Wire bits of any type except twisted bits
 - b. Boots or wraps of any type
 - c. Spurs
 - d. Gag bits

Hunt Seat Equitation

1. USEF Chapter "EQ" -- Subchapters: Eq-1 & Eq - 2, WSH
2. Lead changes
 - a. Flying lead change may score 0-10 points
 - b. Interrupted lead change may score 0-8 points
 - c. Simple lead change may score 0-6 points
3. Class expectation:
 - a. Good crisp movement of the equine with no resistance and soft flowing bends will score higher.
 - b. Equitation skills with ear, shoulder, hip, and heel alignment while keeping a straight line between bit and elbows are paramount. The finished team will place higher.

- c. Lead changes should be smooth with well executed flying changes receiving higher scores.
 - d. Equine should remain calm showing no resistance to the cues throughout the pattern.
 - e. Attention to every detail will be noted. This is a precision class.
 - f. Bit checks are at the discretion of the judge.
4. Required equipment:
- a. Forward seat saddle
 - b. English bridle
 - c. Regulation snaffle, Pelham, full bridles, kimberwicks, all with cavesson nosebands.
5. Optional equipment, including but not limited to:
- a. Spurs of an English type
 - b. Crops or bats, may carry one whip no longer than 30" including snapper or lash
 - c. Gloves
 - d. English breastplate
 - e. Braiding of mane or mane and tail in hunt style
 - f. ½ chaps
6. Prohibited equipment
- a. Figure 8, flash or dropped nosebands are prohibited.
 - b. Draw reins
 - c. Non English type spurs
 - d. Western or sidesaddles
 - e. Bit converters
 - f. Gag bit
 - g. Ribbon, glitter and sparkle (exception: residual from working pairs when scheduling does not allow it's removal.)
 - h. Martingales
 - i. Protective boots, leg wraps and bandages
 - j. Cut back saddle
 - k. Gaited horses shall NOT be shown with chains on feet

Hunt Seat Equitation Over Fences

1. USEF Chapter "EQ" & "HU"
2. Refusals and deductions
 - a. Mandatory score deductions will be made and noted on the score sheet in the space provided. Judges may also factor the refusal into their element score at their discretion.
 - i. First refusal shall incur a deduction of 3 points.
 - ii. Second refusal shall incur a deduction of 5 points for a total of 8 points.
 - iii. Three (3) combined refusals when on course is an elimination.
3. Fences will have a height or spread of 2'6" (2 feet, 6 inches) to 2'9" (2 feet, 9 inches).
 - a. Breakaway jump cups shall be used on rear rail of Oxer jumps. USEF approved mechanical breakaway cups are highly recommended but an unsharpened pencil can be used as the jump cup pin if the breakaway jump cups are not available.

- b. A walk through of the course by participating athletes will be held prior to commencing competition.
4. The officiating judge may deem an athlete non-competent to jump and that decision will stand. The officiating judge may excuse any athlete he/she feels is unsafe.
5. Class expectations:
 - a. Downed fences that are to be jumped a second time in the remaining execution of the course will be reset prior to second attempt.
 - i. For safety reasons Judge may ask rider to drop to trot and circle until jump is reset.
 - b. Athlete should have a workmanlike appearance, seat and hands being light and supple, conveying the impression of complete control.
 - c. Hands should be above and in front of equine's withers, knuckles thirty degrees inside the vertical, hands slightly apart and making a straight line from equine's mouth to athlete's elbow. Method of holding reins is potential and bight of reins may fall on either side.
 - d. In basic position, the eyes should be up and shoulders back. Toes should be at an angle best suited to the athlete's conformation. Ankles should be flexed in, heels down, calf of leg in contact with equine and slightly behind the girth. Iron should be on the ball of the foot and must not be tied to the girth.
 - e. The position at a canter should be a couple of degrees in front of the vertical; posting trot, inclined forward, galloping and jumping, same inclination as the posting trot.
 - f. The performance begins when the equine enters the arena or is given the signal to proceed after entering the arena.
 - g. The following will result in elimination:
 - i. Fall of equine and/or athlete
 - ii. Three cumulative refusals - score will not be tallied and athlete receives a participation point.
 - iii. Off course
 - iv. Non-competent to jump (as determined by the judge) - athlete receives no participation point.
 - h. With the judge's permission, an eliminated athlete may make one attempt to jump an additional single object but may not continue thereafter.
 - i. The following constitute major faults and will be scored accordingly:
 - i. A refusal
 - ii. Loss of stirrup
 - iii. Trotting on course when not part of a test
 - iv. Loss of reins
 - j. Each athlete may circle once before approaching the first fence and once upon completion of the pattern.
 - k. Bit checks are at the discretion of the judge.
6. Required equipment
 - a. Forward seat saddle
 - b. English bridle
 - c. Regulation snaffle, Pelham, full bridles, Kimberwick, all with cavesson nosebands.

7. Optional equipment, including but not limited to:
 - a. Spurs of an English type
 - b. Crops or bats, may carry one whip no longer than 30" including snapper or lash
 - c. Gloves
 - d. Martingale
 - e. English breastplate
 - f. Braiding of mane or mane and tail in hunt style
 - g. ½ chaps
8. Prohibited equipment
 - a. Draw reins
 - b. Non English type spurs
 - c. Western or side saddles
 - d. Bit converters
 - e. Gag bit
 - f. Ribbon, glitter and sparkle (Exception: residual from working pairs when scheduling does not allow its removal.)
 - g. Cut back saddle
 - h. Gaited horses or any equine shall NOT be shown with chains on feet.

In Hand Obstacle Relay

1. Required equipment
 - a. Headgear is not optional. Helmet or appropriate hat for the seat displayed by athletes should be used.
2. Eligibility
 - a. This is a 4-person team event.
 - b. Schools with only 2 or 3 eligible competing athletes will be allowed to participate using 4 different equine.
3. Timing
 - a. Each team is allowed 5 minutes to complete the course
 - b. Any team exceeding the 5-minute allotment shall be assessed a 10-point penalty for each minute or fraction of a minute in violation.
 - i. 5:01-6:00 minutes 10 point penalty
 - ii. 6:01-7:00 minutes 20 point penalty
 - c. Teams will be signaled to stop after 7 minutes on course.
 - i. All points earned prior to the stop at 7 minutes will count
 - ii. A thirty second warning will be given.
 - iii. When time is called, the athlete on course will not continue.
 - iv. Teams will receive all scores to that point, and will accrue appropriate time penalties.
4. Class expectations
 - a. Only the Athlete on course may reset obstacles. Resetters will only reset course between teams.
 - b. Hand aids, without touching the equine, are allowed.
 - i. Athletes may touch the equine when directed by the judge or specified in the pattern.

- ii. Athletes touching equine should not expect “0”, but will be scored accordingly.
 - c. Gaits/side of the equine between obstacles are optional unless specified in the pattern
 - d. This is a horsemanship class! Equine and athletes should be properly groomed as in a Showmanship class.
 - e. Maneuvers should be crisp and practiced. Only the very best should attempt the “BONUS” obstacle element.
 - f. Equine should show no resistance to the handler during any maneuver and should appear as if not on a lead rope.
 - g. Equine should move quickly but maintain the superior ground manners that one would expect in a showmanship class.
5. Each contestant may earn up to 10 points for navigating each of the mandatory obstacles. IHOR contestants will be judged on performance of the handler and horse as they negotiate each obstacle.
 6. Each team member may earn up to an additional 10 points for the team by completing the bonus obstacle. The mandatory obstacles must be attempted BEFORE a contestant will receive points for completing the bonus obstacle.
 7. All team members shall be positioned behind the 30’ start/finish line in the arena. Time starts when the first handler or equine breaks the plane of the starting line. The next contestant cannot break the plane of the start line until the contestant on course (handler) has crossed the start/finish line. Time shall end when the fourth handler or equine breaks the plane of the start/finish line.
 8. Contestants will not be DQ’d for scratching (when two handlers are determined to be on the course at the same time) at the start/finish line. A team in violation will be given a 10-point penalty for each occurrence.
 9. Points will be added up for all mandatory and bonus obstacles for each contestant and added together with the other team members to determine total team score. Penalty points will be deducted from the team’s total to determine the final teamscore.
 10. All In Hand and riding equine are eligible for this event.
 11. Time will only be used as a tie breaker with the exception of points being deducted for times exceeding the 5 (five) minute time limit.
 12. Required Equipment
 - a. Halter and lead rope or leather lead
 13. Optional Equipment, including but not limited to:
 - a. Gloves
 - b. Nose or chin chains (for the equine)
 - c. Leg wraps
 - d. Ribbons, glitter and sparkle on horses
 14. Prohibited Equipment
 - a. Bridles of any type
 - b. Whips, crops or bats
 - c. Spurs
 - d. Chaps or chinks

Trail

1. Class expectations:
 - a. Attention to detail and educating the equine to negotiate the obstacles makes this class easy. Horsemanship knowledge in displaying fundamentals is important. Accuracy, smoothness and acceptance of obstacles should be points of training. Refusals will deduct points.
 - b. Judges will be looking for a “finished” equine/rider team in this event. Gaits around and over obstacles should be smooth and obedient.
 - c. Hand carried items shall be held in one hand and reins in the other.
 - d. Athletes and equines should create a working team. Movement through and over obstacles should be crisp while allowing the equine to negotiate each set up. Leads should be accurate and backing should be precise but not too slow. Haunch turns, pivots, lateral movements and backing should be smooth with continual movement. Delay of pattern will cost points.
 - e. Two refusals will require moving on to the next element.
 - f. Bit checks are at the discretion of the judge.
 - g. Reins must be held properly for the type of reins used.
2. Required Equipment:
 - a. Western
 - i. Western saddle with horn
 - ii. Western bridle
 - iii. There shall be no discrimination against any standard western bit. Standard western bit is classified as having a curb chain or strap and a shank to create leverage.
 - iv. All snaffle bits and rawhide bosals may be used on junior equines.
 1. Junior equines are defined as equines 5 years old and under
 - v. No snaffles on horses 6 years of age and older.
 1. Documentation of equine’s age may be requested.
 2. The use of the snaffle on a horse the age of 6 (six) years or older shall be considered prohibited.
 - b. English
 - i. Hunt Seat
 1. Forward seat saddle
 2. English bridle
 3. Regulation snaffle, Pelham, full bridle, Kimberwick, all with cavesson nosebands.
 - ii. Saddle Seat
 1. Full bridles with cavesson (curb and snaffle) or pelham bit with two (2) sets of reins
 2. Gaited horses may opt to use a breed appropriate single rein bit
 3. Cut back saddle
3. Optional Equipment, including but not limited to:
 - a. Western
 - i. Rope or riata - if used, the rope must be attached to the saddle
 - ii. Spurs

- b. English
 - i. Crops or bats
 - ii. Spurs
- c. Gloves
- 4. Prohibited Equipment
 - a. Western
 - i. Jerk lines
 - ii. Tack collars
 - iii. Chaps & half chaps
 - iv. Whips, crops or bats
 - v. Wire chin straps regardless of padding or covering
 - vi. Any chin strap narrower than ½ inch
 - vii. Sidesaddle or any type of English saddle
 - viii. Nosebands and tie downs
 - ix. Chinks
 - b. English
 - i. Non English style spurs
 - ii. Western, Dressage or side saddles
 - iii. Figure 8, flash, or dropped noseband
 - iv. Bit converters
 - c. Martingales or draw reins
 - d. Slip or gag bits
 - e. Protective boots, leg wraps and bandages
 - f. Ribbon, glitter and sparkle (Exception: Residual from working pairs when scheduling does not allow for its removal)
 - g. Gaited horses or any equine shall NOT be shown with chains on feet

In Hand Trail

1. Required Equipment
 - a. Head gear is not optional - Helmet or appropriate hat for the seat displayed by athletes should be used.
2. Cross entry between In Hand Trail and mounted Trail is permitted.
3. Course design
 - a. The same course with the same dimensions will be used for both horse and pony/mini.
4. Hand aids are permitted.
 - a. Athletes may not touch equine unless directed by the judge or specified in the pattern.
 - b. Athletes touching their equine should not expect a zero but will be scored accordingly.
5. This class will be using the regular trail course, with alterations to allow for animals to be shown in hand.
6. To be judged the same as a regular trail course.
7. Bridges are crossed by horse and handler
8. In Hand trail equine are not restricted to size or breed

9. Class expectations:
 - a. Attention to detail and educating the equine to negotiate the obstacles makes this class easy. Horsemanship knowledge in displaying fundamentals is important. Accuracy, smoothness and acceptance of obstacles should be points of training. Timing will count. Refusals will deduct points. Judges will be looking for a "finished" equine/athlete team in this event.
 - b. Gaits around and over obstacles should be smooth
 - c. Hand carried items shall be held in the hand opposite the leading hand.
 - d. Athletes and equines should create a working team. Movement through and over obstacles should be crisp while allowing the equine to negotiate each set up. Haunch turns, pivots, lateral movement and backing should be smooth with continual movement. Delay of pattern will cost points.
 - e. Two refusals will require moving on to the next element.
 - f. It should appear that the horse is working without the use of a lead rope exhibiting no resistance.
10. Required Equipment
 - a. Halter and lead rope or leather lead
11. Optional equipment, including but not limited to:
 - a. Gloves
 - b. Nose or chin chains (for the equine)
12. Prohibited equipment
 - a. Bridles
 - b. Whips, crops or bats
 - c. Spurs
 - d. Chaps, chinks
 - e. Leg wraps
 - f. Ribbons, glitter and sparkle on horses

Reining

1. Pattern selection
 - a. USEF or NRHA approved reining patterns will be used.
2. Lead changes
 - a. Flying lead changes are required and should be attempted. Horses attempting flying lead changes and not completing them will be scored accordingly.
 - b. Horses not attempting a flying lead change and performing other changes will be given a score of 0 for the element.
3. Reining elements may be given a score of zero. All other element scores will be tallied and awarded to athlete. The athlete will not be disqualified unless using prohibited or inhumane equipment.
4. Arena set up
 - a. Markers (such as cones) will be placed on the wall or fence of the arena at the center of the arena and at least 25' from each end wall. A total of 6 cones is required.

5. Class expectations
 - a. "Reining is the dressage of western riding" is a common description of this class and for good reason. Particular attention to placement of the cones, center markers and judge position are all critical to the performance. Use of the arena is paramount and deductions are made for staying too close to the walls.
 - b. Though "run" is a professional term used in reining, the development of speed in this class determines the quality of the rider's horsemanship. Body "language" and that communication with the equine during each maneuver will be scored.
 - c. Transitions from fast to slow should be evident, with circles round and consistent. Sliding stops should be smooth, not "popping". Equines should remain calm during the rollback maneuvers without hesitation.
 - d. Bit checks are at the discretion of the judge.
6. Required equipment
 - a. Split reins - when used with a curb bit may be held in one of two ways:
 - i. One finger between the reins with the bight of the rein falling on the same side as the rein hand.
 - ii. Romal style with all fingers wrapped around the reins and with the bight held in the opposite hand. There can be no fingers between the reins when held in a romal style.
 - b. Western saddle with horn
 - c. Western bridle
 - d. There shall be no discrimination against any standard western bit. Standard western bit is classified as having a curb chain or strap and a shank to create leverage.
 - e. All snaffle bits and rawhide bosals may be used on junior equines.
 - i. Junior equines are defined as equines 5 years old and under.
 - f. No snaffles on horses 6 years of age and older
 - i. Documentation of equine's age may be requested
 - ii. The use of a snaffle on a horse the age of 6 (six) years or older shall be grounds for elimination.
7. Optional equipment, including but not limited to:
 - a. Gloves
 - b. Rope or riata - if used the rope or riata must be coiled and attached to the saddle
 - c. Western spurs
8. Prohibited equipment
 - a. Roping reins
 - b. Jerk lines
 - c. Tack collars
 - d. Hackamores of any type
 - e. Chaps and half chaps
 - f. Whips, crops and bats
 - g. Slip or gag bits
 - h. Wire chin straps regardless of padding or covering
 - i. Any chin strap narrower than ½ inch
 - j. Martingales and draw reins
 - k. Nosebands and tie downs

- l. Chinks
- m. Sidesaddle or any type of English saddle
- n. Gaited horses or any equine shall NOT be shown with chains on feet

Saddle Seat

1. USEF Chapter "EQ" -- Subchapters: Eq - 1 & Eq - 3, WSH
2. Uniform
 - a. Saddle seat pants may have pinstripes
3. "Intermediate gait" will be allowed in place of trot for gaited horses in patterns.
4. Lead changes
 - a. Interrupted lead changes are the expectation and may score 0-10 points
5. Class expectations:
 - a. Proper body and hand position is of the utmost importance, with hands elevated but keeping a straight line between bit and elbows and using light contact with the equine's mouth.
 - b. Body position with ear, shoulder, hip and heel alignment will be closely observed in this pattern.
 - c. Use of the arena to best display the equine's ability and athlete's horsemanship will score higher points. Animated movement of the equine with no resistance to hand or leg cues during the pattern, maintaining the ability to collect during lead changes and transitions is going to contribute to the overall success of this performance.
 - d. Bit checks are at the discretion of the judge.
6. Required equipment
 - a. Full bridles with cavesson (curb and snaffle) or pelham bit with two (2) sets of reins
 - i. Gaited horses may use breed specific bridles
 1. Single curb bit with a single rein
 - b. Cut back saddle
7. Optional equipment, including but not limited to:
 - a. Spurs of an English type
 - b. Gloves
 - c. A whip may be used but may be no longer than 48" including the snapper or lash.
8. Prohibited equipment
 - a. Draw reins
 - b. Non English type spurs
 - c. Western or side saddles
 - d. Bit converters
 - e. Gag bit
 - f. Ribbon, glitter and sparkle (Exception: residual from working pairs when scheduling does not allow its removal.)
 - g. Figure 8, flash, or dropped noseband
 - h. Martingales
 - i. Protective boots, leg wraps and bandages
 - j. Gaited horses or any equine shall NOT be shown with chains on feet.

Showmanship

1. USEF, WHO
2. Head gear is not optional
 - a. Helmet or appropriate hat for the seat displayed by athletes.
3. Hand aids are permitted
 - a. Athletes may not touch equine unless directed by the judge or specified in the pattern.
 - b. Athletes touching their equine should not expect a zero but will be scored accordingly.
4. In showmanship classes, the athlete may show according to the showmanship specifications of the breed of his or her equine. Showmanship is a demonstration of the athlete's ability to show the equine to its best advantage in hand.
5. Haunch turns should have forward motion
6. Conformation of the equine is not to be considered
7. The lead should be 6' to 8' in length
8. Class expectations
 - a. Showmanship should also be called SALESMANSHIP. The athlete should exhibit their equine with extreme confidence in the equine and themselves. Elements should be smooth and accurate. Flowing motion, rather than start, stop motion is preferred.
 - b. We are not looking for the athlete to rush through the pattern but rather create a presence that convinces the judge that their equine partner is at its best and that they have nailed every element of the pattern. Eye contact with the judge, crisp body communication and facial expression are all part of this ground class.
 - c. Changes of sides should show the willingness of the equine to yield to the athlete under any circumstance. Condition of coat, feet, mane, and tail does not count in this class.
 - d. Equines should display no resistance. Lead rope and halter should be outfitted correctly, but appear to not be necessary in the equines performance.
9. Required Equipment
 - a. Halter and lead rope or leather lead
10. Optional equipment, including but not limited to:
 - a. Gloves
 - b. Nose or chin chains (for the equine)
 - c. Full bridle (in Hunt seat or Saddle Seat attire only)
11. Prohibited Equipment
 - a. Bridles of any type (except as noted above)
 - b. Whips, crops or bats
 - c. Spurs
 - d. Chaps/chinks
 - e. Leg wraps
 - f. Ribbon, glitter, and sparkle on horses (Exception: residual from working pairs when scheduling does not allow its removal.)

Western Horsemanship/Stock Seat Equitation

1. USEF, WSH
2. Lead changes
 - a. Flying lead change may score 0-10 points
 - b. Interrupted lead change may score 0-8 points
 - c. Simple lead change may score 0-6 points
3. Disqualifications
 - a. An athlete using two hands on a curb bit, or one hand on a snaffle bit, is considered to be using permitted equipment illegally and will be disqualified.
 - b. If the athlete enters the arena and begins the pattern correctly holding the reins, the athlete will not be disqualified but will receive a "0" on every element ridden illegally.
4. Class expectations
 - a. Equitation skills in performing smooth elegant maneuvers score higher. Understanding what the pattern calls for will enhance the performance.
 - b. In this pattern, correct flying lead changes will score higher.
 - c. Attention to detail while using the arena area to your best advantage will show off your horsemanship to the best advantage. Performing crisp accurate movement is preferred.
 - d. Backing should be smooth and resistance free with rider aids unobserved. Equine should appear to enjoy the backing elements.
 - e. This is an equitation class. Body position of the athlete is scored. Behavior of the equine is the direct result of the athlete's horsemanship skills.
 - f. Bit checks are at the discretion of the judge.
5. Required equipment
 - a. Split reins, when used with a curb bit may be held one of two ways
 - i. One finger between the reins with the bight of the rein falling on the same side as the rein hand.
 - ii. Romal style with all fingers wrapped around the reins and with the bight held in the opposite hand. There can be no fingers between the reins when held in a Romal style.
 - b. Western saddle with horn
 - c. Western bridle
 - d. There shall be no discrimination against any standard western bit. Standard western bit is classified as having a curb chain or strap and a shank to create leverage.
 - e. All snaffle bits and rawhide bosals may be used on junior equines.
 - i. Junior equines are defined as equines 5 years old and under.
 - f. No snaffles on horses 6 years of age and older
 - i. Documentation of equine's age may be requested
 - ii. The use of a snaffle on a horse the age of 6 (six) years or older shall be considered prohibited
 - g. Optional equipment, including but not limited to:
 - i. Gloves

- h. Rope or riata - if used the rope or riata must be coiled and attached to the saddle
 - i. Western spurs
6. Prohibited equipment
- a. Roping reins
 - b. Jerk lines
 - c. Tack collars
 - d. Chaps and half chaps
 - e. Whips, crops and bats
 - f. Slip or gag bits
 - g. Wire chin straps regardless of padding or covering
 - h. Any chin strap narrower than ½ inch
 - i. Martingales and draw reins
 - j. Sidesaddle or any type of English saddle
 - k. Nosebands and tie downs
 - l. Chinks
 - m. Protective boots, leg wraps and bandages
 - n. Gaited horses or any equine shall NOT be shown with chains on feet

Working Pairs

1. Costume
 - a. Flags on flagpoles may be carried as part of the costume element in conjunction with a flag boot.
 - b. Other than flags (as stated above), no part of the costume may be held by the athlete.
 - c. Face paint and hair/and or helmet decoration is allowed.
 - d. Any costume deemed unsafe by the judge will result in an elimination.
2. Degree of difficulty
 - a. Any bit may be used in this class, and reins may be held by any safe method.
 - b. Two hands on a western curb will be given a lower degree of difficulty score than reins carried conventionally.
 - c. Martingales and tie downs are legal but may also reduce the degree of difficulty score.
3. Equine equipment shall meet requirements for chosen style of riding. (Except any age equine may use a snaffle or bosal. Snaffle can be Western or English and bosal or mechanical hackamore is Western only).
 - a. Working Pairs may be ridden in English (Saddle Seat, Hunt Seat, Dressage) or Western equipment with corresponding attire
 - b. Both riders must ride with the same type of equipment. Mixing English bridles with Western saddles or Western bridles with English saddles is prohibited.
 - c. Both riders must ride the same seat; both Western, both Hunt Seat or both Saddle Seat
4. Working Pairs is to be ridden in an arena using Dressage symbols for orientation. The arena should be fairly close in size to a small dressage arena (65' x 130' approx.) without using any type of borders or boundaries.

5. Class expectations
 - a. This class is judged on individual horsemanship skills, which include correct leads, balanced gaits, transitions and overall uniformity. Smooth and quiet use of aids to maintain conformity is essential
 - b. Timing at the halt and stop should be simultaneous and equines should be balanced, facing forward. Backing should also be simultaneous, equines together, riders shoulder to shoulder. Use of the arena and timing of transitions and lead changes will be evaluated for score.
 - c. Riders should always mirror each other, even when apart.
 - d. The pattern should be smooth overall and the music and decoration on the equines should enhance the performance and can be evaluated in the overall score.
 - e. The close, salute and turn should also be in unison.
 - f. Because of safety issues it is vital that leads be correct and equine be in unison at the lope or canter.
 - g. Scoring shall include a 10-point cumulative bonus for costumes and music.
6. Required arena equipment:
 - a. All small dressage arena letters (A, K, E, H, C, M, B, F)
7. Optional equipment
 - a. Costume for athlete limited to face paint, hair and helmet decoration
 - i. The only facial decoration allowed for Working Pairs shall be facepaint
 - b. All humane bits regardless of horse's age
 - c. Any age equine may use a snaffle or bosal. Snaffles can be Western or English and bosal or mechanical hackamore in Western only.
 - d. Gloves
 - e. Rope or riata; if used, the rope or riata must be coiled and attached to the saddle.
 - f. Spurs
 - g. Individual music
 - h. Costume and/or decorations for horse such as glitter and sparkles
 - i. Leg wraps
 - j. Nosebands and tie downs. The tie down must be attached to or under the breast collar.
 - k. Martingales
 - l. ½ Chaps & chinks
 - m. Sunglasses
 - n. Breast collar or English breastplate
 - o. Flags on flag poles may be carried as part of the costume element in conjunction with a flag boot.
8. Prohibited equipment
 - a. Wire chin straps, regardless of how padded or covered
 - b. Decoration and/or costuming of team uniform
 - c. Any chin strap narrower than ½ inch
 - d. Draw reins
 - e. Jerk lines
 - f. Tack collars
 - g. Chaps

Working Rancher

1. Course design
 - a. Cattle may be incorporated into an obstacle on the course.
2. Disqualifications
 - a. An athlete using two hands on a curb bit, or one hand on a snaffle bit, is considered to be using permitted equipment illegally and will be disqualified.
 - b. If the athlete enters the arena and begins the pattern correctly holding the reins, the athlete will not be disqualified but will receive a "0" on every element ridden illegally.
 - c. Exception - proper negotiation of an obstacle may require a rider to use one hand on a snaffle or bosal temporarily.
3. Class Expectations
 - a. The working rancher should have the ability to keep the equine moving forward at a smooth even tempo. There should be time for the equine to negotiate each obstacle just as on the ranch but there should be no refusals or hesitation when asked to perform any task.
 - b. Rider aid should be used quietly and unobserved, completing one element and getting ready to execute the next without undue jerking and pulling on the equine.
 - c. This pattern is designed to show the athlete's expertise in the proper use of ropes, keeping the equine under control and completing the ranch job with the least amount of energy involved. Excess use of bit and reins should be avoided and noted in the score.
 - d. Though this pattern should be ridden with more speed and purpose than trail, the athlete should have a willing and relaxed equine at all times.
 - e. Athletes may use two hands with snaffle bit or bosal only on junior horses (5 years old and under).
 - f. Bit checks are at the discretion of the judge
 - g. Only 1 (one) attempt at roping the calf head is allowed
4. Required equipment
 - a. Western saddle with horn
 - b. Western bridle
 - c. Roping, Romal or Mecate reins
 - i. Split reins-when used with a curb bit may be held one of two ways
 1. One finger between the reins with the bight of the rein falling on the same side as the rein hand.
 2. Romal style with all fingers wrapped around the reins and with the bight held in the opposite hand. There can be no fingers between the reins when held in a Romal style.
 - d. Required rope: unless the pattern states otherwise, the rope should be coiled and attached to saddle.
 - e. There shall be no discrimination against any standard western bit. Standard western bit is classified as having a curb chain or strap and a shank to create leverage.
 - f. All snaffle bits and rawhide bosals may be used on junior equines.
 - i. Junior equines are defined as equines 5 years old and under.

- g. No snaffles on horses 6 years of age and older
 - i. Documentation of equine's age may be requested
 - ii. The use of a snaffle on a horse the age of 6 (six) years or older shall be considered prohibited
- 5. Optional equipment, including but not limited to:
 - a. Gloves
 - b. Chinks
 - c. Breast collar (strongly suggested)
 - d. Protective boots or wraps
 - e. Noseband and tie down (must be secured to or behind the breast collar)
 - f. Western spurs
- 6. Prohibited equipment
 - a. Jerk lines
 - b. Tack collars
 - c. Hackamore
 - d. Chaps and half chaps
 - e. Whips, crops and bats
 - f. Slip or gag bits
 - g. Wire chin straps regardless of padding or covering
 - h. Any chin strap narrower than ½ inch
 - i. Martingales and draw reins
 - j. Sidesaddle or any type of English saddle
 - k. Gaited horses or any equine shall NOT be shown with chains on feet

Team Versatility

1. Schools with only 3 eligible competing athletes may compete with 4 different equines.
2. For the Trail/Working Rancher section of the event:
 - a. Trail or Working Rancher equipment may be used in either Trail or Working Rancher chosen pattern.
 - b. If there is a rope required for the Trail/Working Rancher pattern then roping reins are required.
3. Timed event riders not stopping and/or proceeding into the other horse/handlers in an unsafe manner will be disqualified.
4. Equipment
 - a. All equipment, required and optional shall follow the rules of the specific discipline of each athlete. For example, the Timed event rider will follow Timed Event rules for equipment, the Equitation rider will follow the rules of whichever discipline they are riding in this event and so on.
 - b. Athlete attire must match their tack and equipment
 - c. Decoration of horses is allowed.
5. There are four disciplines in each course and the final category is overall time. One athlete will represent each discipline, except when rule (1) is being followed; in which case, one athlete will compete in two disciplines on two different horses.

- a. The disciplines will be done in the following order:
 - i. In Hand
 - ii. Trail/Rancher
 - iii. Equitation
 - iv. Timed
6. In Hand
 - a. This discipline may be attired in either English or Western and the athlete will always work with their horse from the ground.
 - b. Elements of this part of the event will include anything you might find in one of our in hand classes, including but not limited to: walk/trot overs, haunch and forehand turns, leading, backing, sidepassing, etc.
7. Trail/Working Rancher
 - a. This discipline might include any element you would find in a trail or working rancher event. Including, but not limited to: roping a dummy, walk, jog, lope overs, picking up objects, etc.
8. Equitation
 - a. This discipline may best be ridden either Western or Hunt Seat Equitation, but if an element is appropriate, could also be ridden Saddle Seat Equitation.
 - b. Elements might include any part of a typical Western or English Equitation pattern. Including, but not limited to: lead changes, haunch and forehand turns, upward and downward transitions, etc.
9. Timed Event
 - a. This part of the event will be independently timed. This means every athlete should have an official time from the break of the start line to the break of the finish lane.
 - i. Time should be at least to the hundredth, but could be to the thousandth if equipment allows.
 - b. This element of the event will include the type of obstacles used in our timed, non-cattle events. For example, items might include turning barrel, picking up a flag, weaving a couple poles, etc.
 - c. Knockdowns, and other time penalties incurred, per our Timed Event Rules, will be assessed a 5 second penalty for each.
 - d. Off course and other "No Time" violations will follow the same rules as our Timed Event section, receiving a no time. If two teams have a tie for this element then it will be handled as all event ties are handled. For example: If two athletes are tied for 3rd fastest time in the Timed Event element, each athlete's team will receive 3rd place points and 4th place will be skipped. The next athlete's team will be awarded 5th place points.
10. Overall Time
 - a. An Overall Time for each team is added to at least the hundredth (could be the thousandth if equipment allows, measured from the first break of the plane until the final horse/rider breaks the plane upon completion.

- i. Overall Times are then placed in order and awarded the following points as a scored element of the course.
 - 1. 1st Place receives 10 points
 - 2. 2nd and 3rd place receive 9 points
 - 3. 4th and 5th receive 8 points
 - 4. 6th and 7th receive 7 points
 - 5. 8th receives 6 points
 - 6. 9th receives 5 points
 - 7. 10th receives 4 points
 - 8. All others with an overall time receive 2 points
- ii. If two teams have a tie for overall time then it will be handled as all event ties are handled. For example: if two teams are tied for 3rd place, each team will receive 3rd place points and 4th place will be skipped. The next team will be awarded 5th place points.

11. Event Set Up

- a. The start/finish line will include 3 poles and two cones.
 - i. Chalk start line will be used under the timer line with the exception of the timed event lane.
 - ii. Both side poles should be at least 2' off the wall
 - iii. The timed event section must be at least 30' wide
 - iv. Electronic timers if used should be placed at the timed event poles on the start line.
 - v. There will be a designated "stop box" for the timed event riders, it should be at least 30'x30', but can be as large as possible, leaving room for the other 3 horses to safely wait for completion of the run.
 - 1. Timed event riders not stopping in the box will receive a no time.
 - 2. Timed event riders not stopping and/or proceeding into the other horse/handlers in an unsafe manner will be disqualified.
 - vi. Area between Timed event "inside" pole and cones may be disbursed appropriate to elements drawn for the event. See diagram below.....

12. Event Procedure

- a. Several maneuver options for each discipline will be supplied with patterns annually.
 - i. Draw for maneuvers on the first day of PNWIC
 - ii. Draw one maneuver from each discipline.
 - 1. This is best if witnessed by a group.
 - iii. These four maneuvers (1 in each discipline) make up the course.
- b. All teams perform the same maneuvers.
- c. All team members will enter at the same time and be positioned behind the start/ finish line.
 - i. The first athlete will break the plane of the start line onto the course, the next athlete may not break the plane of the start line until the athlete on course returns and is completely over the line and off course.
 - 1. Two athletes on the line will be assessed a 10 point penalty for each occurrence.
 - ii. This process continues until all 4 disciplines are complete.

- iii. The Timed Event rider must stop completely (NOT still, just controlled and a clear halt) in the “stop box” before returning to the other athletes on the team and/or exiting.
- d. Two official times are required and may be manual, electronic, or a combination of timers
 - i. The overall time, from the first athlete breaking the plane until the last athlete breaks the plane upon finishing. This time will be used as an element of scoring
 - ii. The timed event athlete, must be timed independently (just on their run)

13. Scoring

- a. Each discipline/element, except the Timed Event is given a score of 1 to 10, 10 being perfect score definitions that mimic other scores throughout PNWIC.
- b. The timed event independent time is recorded on the scoresheet
 - i. Later in the office, this time is compared to others from the event and ranked in order, fastest to slowest with the other athletes.
 - 1. Those athletes will be awarded points to add to their team’s overall scores on the following basis:
 - a. 1st Place receives 10 points
 - b. 2nd and 3rd place receive 9 points
 - c. 4th and 5th receive 8 points
 - d. 6th and 7th receive 7 points
 - e. 8th receives 6 points
 - f. 9th receives 5 points
 - g. 10th receives 4 points
 - h. All others receiving a time receive 2 points
 - i. No Time receives 1 point
 - j. A DQ receives ZERO points for the Timed Event element
- c. Penalties may be assessed for the following:
 - i. Two on the line receive a 10 point deduction for every occurrence;
 - ii. Up to 10 points can be deducted for unsafe behavior behind the line, this is at the discretion of the judge
 - iii. A 5 second penalty will be assessed for every timed event element knock down, missed flag, etc. Assessed utilizing the same guidelines as other timed event rules.
 - iv. Timed Event riders not stopping within the designated stop box and proceeding toward the other horses in the arena in an unsafe manner, based on the judge's discretion, may be disqualified.
 - v. All disqualification rules from performance and timed events apply.
 - 1. Any member disqualified equals a 0 (zero) for their performance.

14. Judging will be by official judges; each judge will be able to determine if they are comfortable and qualified to judge this event.

15. At PNWIC, this event should include two judges and an official timer.
 - a. One will judge each discipline, including timing the timed event
 - b. One will manage overall time and watch for “behind the line” deductions
 - i. If these duties are split up differently because of expertise, that is acceptable.

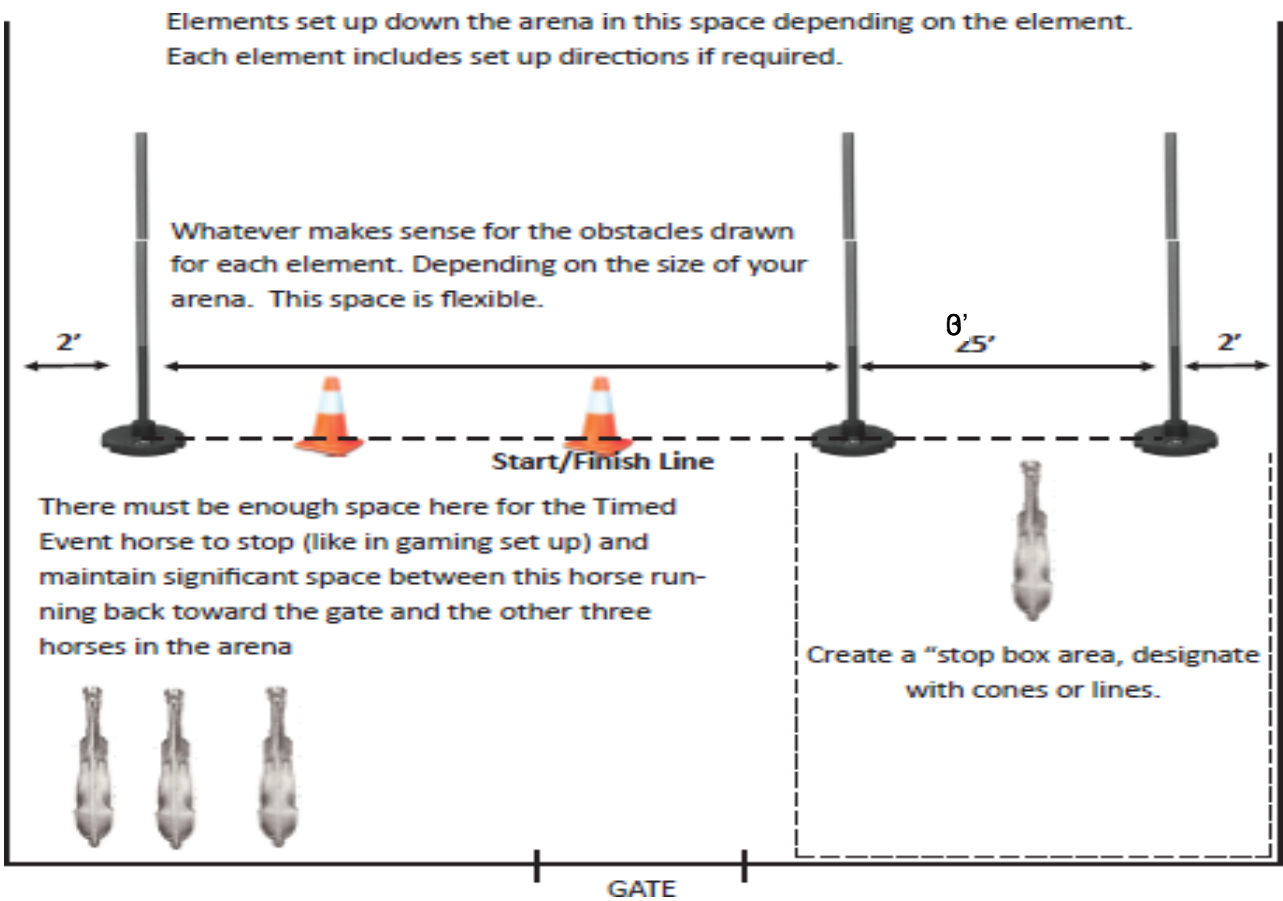

TIMED EVENTS

1. The following classes are covered under this section:
 - a. Barrels (PSHA, WSH)
 - b. Idaho Figure 8 (PSHA, WSH)
 - c. Individual Flags (PSHA, WSH)
 - d. Keyhole (PSHA WSH)
 - e. Pole Bending (PSHA, WSH)
 - f. Two Man Birangle (WSH)
 - g. Team Canadian Flags (WHO)
2. Required equipment
 - a. Bridle or hackamore
 - i. Throat latches are encouraged but not required.
 - b. Western type saddle with horn
 - i. Breast collars are encouraged but not required.
 - c. Roping, Romal or mecate reins
 - d. Breast collar
3. Optional equipment
 - a. Slip or gag bits
 - b. Nose band
 - c. Spurs
 - d. Protective boots, leg wraps, and bandages
 - e. Over and under (to be inspected by judge)
 - f. Tie downs, if used must be attached to or under breast collar
 - g. Martingales, fitted properly as to not be a danger if equine falls or athlete loses control, to be decided by judge
 - h. Regulation snaffle bits
4. Prohibited equipment
 - a. Halters
 - b. Split reins
 - c. Chaps, ½ chaps or chinks
5. Arena set up
 - a. Judges are responsible to oversee, supervise and participate in all course set-ups.
 - b. No chalk start/finish line will be used.
 - c. Chalk passing lines will be used in team timed events.
 - d. Poles and barrels will be provided by hosting state
6. Arena equipment - the following equipment shall be used whenever any of the following terms are used. All equipment is to be standardized according to the applicable specifications.
 - a. Time's equipment:
 - i. Electric clocks - the light and the photocell are to be set on the starting line
 - ii. There will be no back up timers, if the electronic eye fails the athlete will be given a re-ride.

- b. Barrels - fifty-five-gallon plastic barrel, containing eight pounds of dry sand with both ends intact, and set in an inverted position. The ring must be sealed down to the bottom of the barrel. Barrels may be covered.
 - c. Quarter barrels (flag barrels) - painted white and containing 8 to 10 inches of sand or soil. The flag containers to be marked inside the container with a permanent mark, at the 8 to 10 inch point, measured from the bottom of the container up.
 - d. Flags - consists of a staff and a flag. Staff to be 1 inch to 1 1/16 inch wood doweling or other material as approved by the PNWIC Board. Staff is 5 feet long, painted white and planed the full length, or bottom three feet of the staff, to flatten 2 sides. Flag staff to be made out of any kind of wood doweling. Bottom inch tapered to a dull point. Flags to be sturdy material (double thickness, hemmed 8" x 12"), securely fastened to flag staff with nails, brads or large staples, one light and one dark, leaving an 8"x8" portion free from staff.
 - e. Pole bases - black rubber base or black plastic bases filled with a weighted substance. Bases should be 3 inches tall and 14 inches across. Total weight with pole and converter, approximately 17 lbs. (plastic converter is needed to hold pole in base securely).
 - i. Standard 1.5 inch schedule 40 or 80 white plastic pipe, 80 to 81 inches long.
 - ii. Pole base is black, pole must be white. Two pieces of colored tape (2.5" to 3" wide) may be placed 12" down from the top of the pole and the second piece to be placed 24" down from the top of the pole.
 - f. Canadian flags - flag staff to be 42 inches long with the same flag, staff material and dimensions as for individual; flags. The staff will not be planed.
7. Setting up events
- a. In all events except barrels, 2 poles 30 feet apart shall designate the start/finish line. In barrels, the starting poles shall be 60 feet apart.
 - b. Photocell and light to be on the start/finish line.
 - c. When the course is measured, the measurement shall be taken from the center of barrels, poles, containers or other properties or to the lime dot if event property has been moved.
8. Decisions as to penalties, no times and other judging calls will be decided solely by the course judge. During the running of the event, the judge must only be approached by the PNWIC Chairpersons.
9. No athletes/teams may be coached from inside the arena.
10. Resetting the course
- a. In no timed event will the course be reset while the rider is on pattern. The only exception to this would be Canadian Flags, where the rider must retrieve the flag. A dropped flag may be reset before remounting. In all other events, the arena crew will reset downed equipment after riders have run.

- b. Arena safety
 - i. As soon as the athlete takes the course arena staff must close all arena gates. Gate does not have to be closed for individual athletes to start. Gates to remain closed until athlete has completed their run.
 - ii. For team events, gates must be closed prior to starting their run. All athletes must be in the arena and the gate closed before the first rider begins their run.
 - c. Contestants must enter and leave the arena demonstrating control
 - i. Running in the gate is not allowed.
 - d. Only contestants, coaches, advisors, ring crew and officials are allowed in the arena.
 - e. Equine that constitutes a safety hazard may be disqualified
11. Eliminations
- a. Taking more than 30 seconds to cross the starting line.
 - i. The 30 seconds starts after the announcer has announced the athlete and the judge raises their hand with a closed fist or flag indicating the course is ready.
 - b. If any horse waiting its turn crosses the start/finish line before the horse on course crosses the start/finish line completely. There may not be two horses on course at any time.
 - i. Two athletes are determined to be on the course at the same time if the nose of the departing horse crosses the start/finish line prior to the hind feet of the return horse crossing the start/finish line. Tails do not count.
12. Disqualifications
- a. If a helmet comes loose or unbuckled during the run.
 - b. If the athlete touches or adjusts their helmet during the run. If helmet comes loose or unbuckled, it is a disqualification.
13. Athletes off course/elimination - participation points awarded:
- a. Leaving the course, run outs, refusals, upsetting the starting poles or timer eyes
 - b. Taking more than 30 seconds to cross the starting line. The course begins at the start line. Announcer announces athlete, judge raises hand to indicate course is ready, athlete has 30 seconds to start the course whether in arena or not. The judge will time or indicate to the timer to start the 30 seconds. It is a judge's call to "no time" athletes if they have not taken the course.
 - c. Stepping on or outside any of the marked lines of the Keyhole Race. Failure of the equine to have all four feet inside the circle before turning toward the finish line.
14. Athlete disqualification - no points awarded
- a. Intentionally striking the equine with arena equipment.
 - b. Abuse of the equine by any means, including hitting the horse ahead of the elbow in any manner while on course. Touching or patting will not be considered hitting.
 - c. Inhumane use of equipment

- d. Unsportsmanlike conduct in the arena:
 - i. Use of profane language
 - ii. Unnecessary roughness, abusing the equine
 - iii. Disorderly conduct of any kind
 - e. An unmanageable equine for reasons of safety
 - f. Loose equine defined as separated from and out of control of the athlete. A ground tied horse shall be considered in control.
15. Five (5) second penalties will be given for:
- a. Each knockdown of stake, pole, or barrel on course.
 - b. In the flag race, if the flag is missed putting in the container or the container is upset and the athlete crosses the finish line.
16. Re-rides
- a. Re-rides are to be run after the last rider in that event has run. Re-rides are permitted for:
 - i. Interference by another rider and/or horse (to be determined by judge)
 - ii. Failure of all timing devices provided no disqualification of event has occurred.
 - b. If the re-ride is granted, it will be judged as an entirely new ride, with new penalties and disqualifications.
 - c. Moving a course.
 - i. If moved for safety reasons, riders may choose to either re-run or keep their first time
 - ii. If moved for initial wrong measurement, all riders must re-run
17. Record breaking procedures
- a. After a record breaking run, the show is stopped and the judge will oversee re-measurement of the course. Office staff will fill out the record breaking sheet immediately for the judge's signature.

Barrels

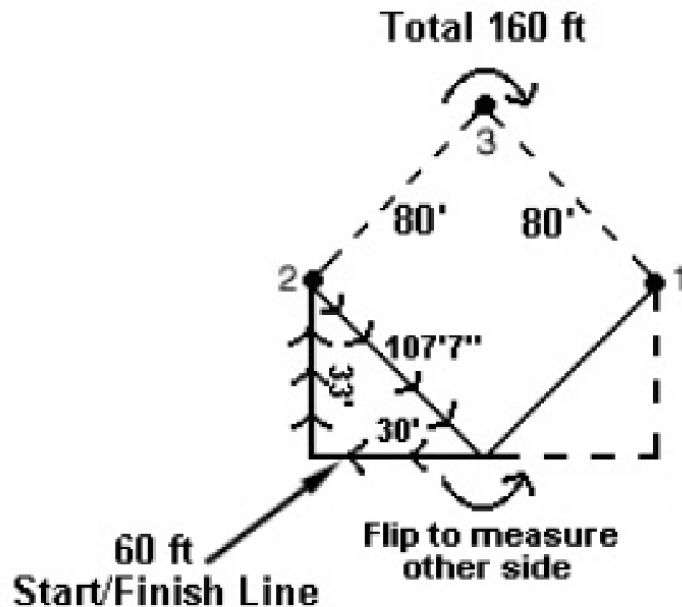

Figure 2-1. Barrel Pattern

1. Course description:
 - a. Three barrels shall be placed in a triangular formation, as shown in Figure 2-1. The number 1 and 2 barrels are set 33 feet from the start/finish line and 60 feet apart. The number 3 barrel is 80 feet from the number 1 and 2 barrels.
 - b. To square the barrels with the arena measure as follows: 30 feet from the middle of the start/finish line (in line with starting line), then 33 feet to the barrel and 107 feet 7 inches back to middle of starting line, making a triangle.
2. Riding instructions:
 - a. Rider crosses the start/finish line, circles the number 1 barrel to right, crosses to the number 2 barrel, circles it to left, the rides to the number 3 barrel, circles it left and races across the start/finish line; or
 - b. Rider crosses the start/finish line to the number 2 barrel, circle it to left, crosses to the number 1 barrel, circles it to right, runs to the number 3 barrel, circles it to right and races across the start/finish line.
3. Knocking over a barrel is a 5 second penalty. Going off course is a "no time". Decisions as to penalties and no time will be decided solely by the course judge.

Idaho Figure 8

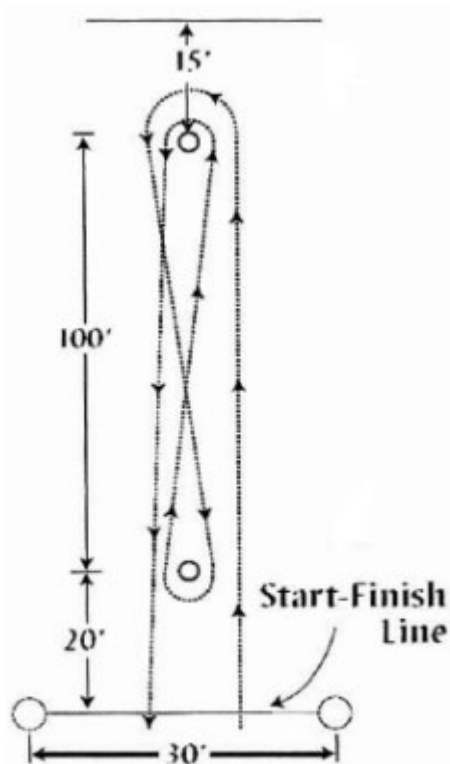

Figure 2-2. Idaho Stake Race Pattern

1. Course description
 - a. Four poles are to be used - two set 100 feet apart at opposite ends of the course. A start/finish line will be established by two poles set 30 feet apart (15 feet either side of the two poles that establish the figure 8) at a distance of 20 feet before the first figure 8 pole. The figure 8 pole at the end of the end of the course opposite the start/finish line will be at least 15 feet from the arena wall, fence or barrier (Figure 2-2).
2. Riding instructions:
 - a. Rider starts by crossing the start/finish line and riding to the opposite end of the course on either side of the figure 8 poles. Rider begins that figure 8 by circling the pole at the end of the end of the course opposite the start/finish line. To complete the figure 8 pattern, rider crosses between the figure 8 poles and turns around the pole closest to the start/finish line in the opposite direction of the first turn, continues back down course and turns around the farthest pole in the same direction as the first turn, then continues back up the side of the course opposite the side started on crosses the start/finish line. Three turns around the poles are required to complete this course.
 - b. Each knock down of a pole will result in a five second penalty

Individual Flags

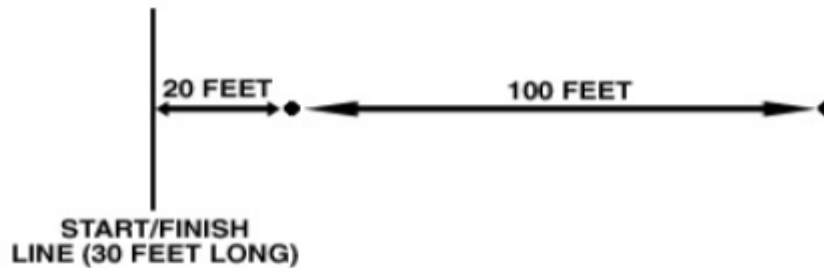

Figure 2-3. Individual Flags Pattern

1. Event uses one 1"-1 1/8" diameter dowel, 5' long and two quarter barrels
2. Course description
 - a. Two quarter barrels are placed 100 feet apart. The first barrel shall be 20 feet from the start/finish line (Figure 2-3). Fill barrels with 8 to 10 inches of sand or soil. Typically, the flags will be oriented in the barrels opposite of each other (left or right) as requested by the rider.
3. Riding instructions
 - a. Upon entering the arena, the rider indicates to the arena crew which hand will be used by raising that hand. The arena crew will then orient the flags in their barrels accordingly.
 - b. The rider crosses the start/finish line, then goes to first barrel and removes the flag from that barrel. The rider then goes around the second barrel, exchanging the first flag for the second one. The rider then goes back to the first barrel, placing the flag from the second barrel into the first barrel, and then crosses the start/finish line.
 - c. The rider may circle the barrel several times if he/she chooses. Individual flags is a "container event", as long as the rider goes around the far flag container the course requirements are met.
4. PENALTIES
 - a. A flag that misses the 3rd barrel (1st barrel) and is carried over the start/finish line will earn a NT.
 - b. If a barrel is upset and the rider crosses the start/finish line, the rider will receive a 5-second penalty per barrel.
 - c. If the barrel is upset during the run, but the rider is able to insert the flag in the upset barrel, but not able to return the barrel to the upright position, only one 5-second penalty is given.
 - d. If the barrel is upset during the run, but the rider is able to insert the flag and return the barrel to the upright position, it is a clean run.
 - e. If a flag is dropped or put into the wrong container, the rider will receive a 5-second penalty for each error.
 - f. Failure to pick up the first (1st) flag will result in a "no time" (NT).

Keyhole

1. Penalties
 - a. If any part of the hoof goes past the entrance of the key hole neck it is a “no time”.
 - i. “Neck” line continues across the arena. It will be considered off course if the horse goes by the entrance lines.
 - b. Stepping on, or outside any lines of the keyhole shall be off course and a “no time” is given. A judge must be at the keyhole to make this determination and his/her decision is final.
2. Course description:
 - a. A keyhole will be marked with lime, as shown in Figure 2-4. The center of the circle will be 100 feet from the start/finish line. The circle will have a radius of 100 feet, the neck length to be 10 feet and the neck width to be 5 feet. Extend the circle to meet the neck.
3. Riding instructions:
 - a. At the starting signal, the rider crosses the starting line, races into the circle of the keyhole, turns his horse and returns back across the start/finish line. All four (4) of the equine's feet must go into the circle.

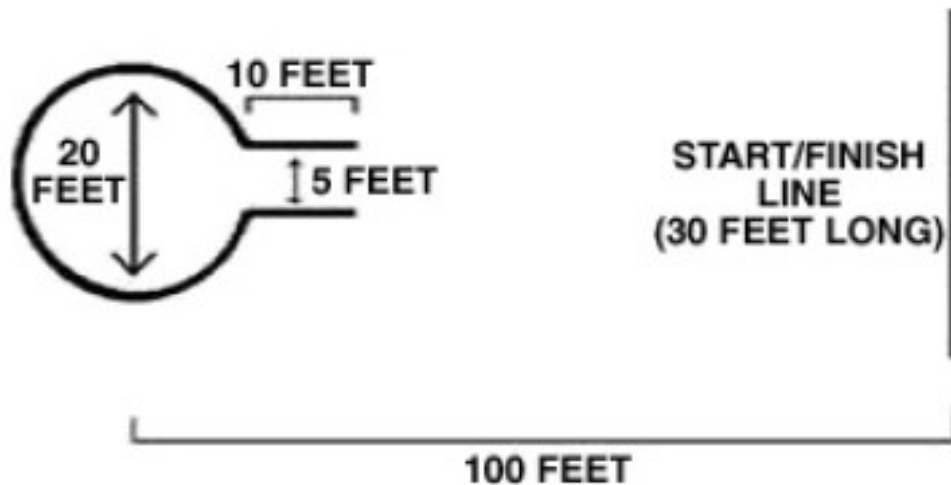

Figure 2-4. Keyhole Pattern

Pole Bending

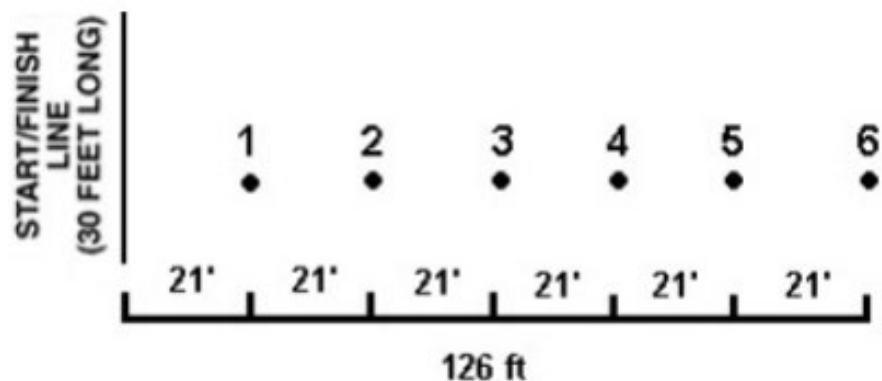

Figure 2-5. Pole Bending Pattern

1. Stepping on or across the start/finish line while turning the pole nearest the start/finish line will result in a "no time", even if the timer continues to run. Tails do not count.
2. Course description:
 - a. Six poles shall be set in a straight line, spaced 21 feet apart with the start/finish line 21 feet in front of the first pole (Figure 2-5)
3. Riding instructions:
 - a. The rider crosses the start line, races to the number 6 pole, pivots and bends back through the poles, pivots around the number 1 pole, bends back through poles, turns and races across the start/finish line.
 - b. The rider may start to the left or right of the poles.
4. Stepping on or across the start/finish line while turning the pole nearest the start/finish line will result in a "no time", even if the timer continues to run. Tails do not count.
5. Each knock down of a pole will result in a 5 second penalty.

Two Man Birangle

1. Unsafe passing
 - a. Teams are encouraged to, but not required to pass (one coming off the course, one going on the course) on opposite ends of the start line.
 - b. A pass deemed unsafe by the judge may be cause for elimination.
2. Course description
 - a. Two poles 30 feet apart shall be placed 120 feet down the course from the start/finish line (Figure 2-6).
 - b. A centerline will be identified at the start/finish line. The centerline will be approximately ten (10) feet in length extending from the off course side of the start/finish line.
3. Riding instructions
 - a. All riders must be in the arena and the gate closed before the first rider begins their run.
 - b. The first rider crosses the start/finish line, then turns either pole from the inside out, then turns the opposite pole from the outside in (either two left or two right turns). The first rider then races across the start/finish line.
 - c. The second rider, once the first rider is off the course, then runs the same course, having the option of which direction to turn first.
 - d. Each knock down of a pole will result in a 5 second penalty. Course will not be reset until the run has been completed by both riders.
4. Contestants will be issued a NO TIME when two athletes are determined to be on the course at the same time. The team will receive participation points.
 - a. Two athletes are determined to be on the course at the same time if the nose of the departing horse crosses the start/finish line prior to the behind feet of the return horse crossing the start/finish line - TAILS DO NOT COUNT

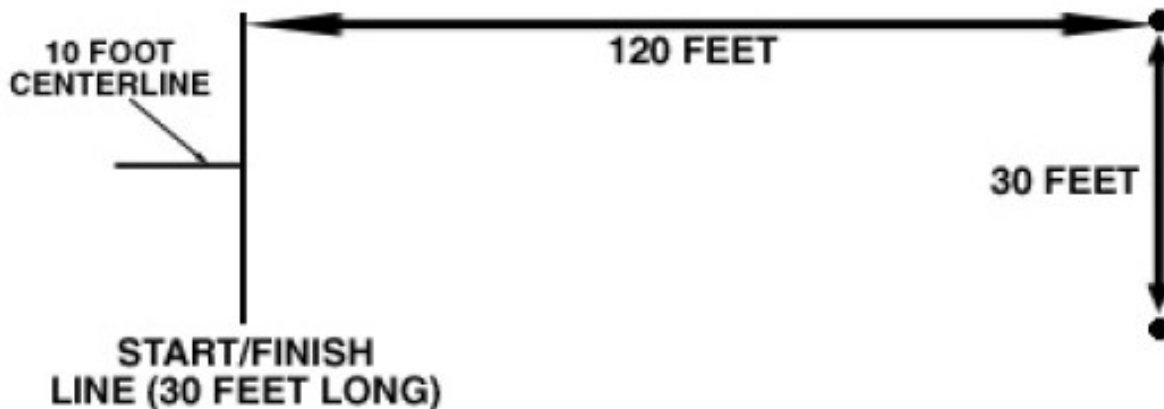

Figure 2-6. Two Man Birangle Pattern

Team Canadian Flags

1. Unsafe passing
 - a. Teams are encouraged to, but not required to pass (one coming off the course, one going on the course) on opposite ends of the start line.
 - b. A pass deemed unsafe by the judge may be cause for elimination.
2. Course description
 - a. Four flags (42 inches in length) shall be spaced at 2 foot intervals, one end in the ground 4 inches, with the first flag 100 feet from the start/finish line and the fourth flag 106 feet from the start/finish line (Figure 2-7).
 - b. A centerline will be identified at the start/finish line. The centerline will be approximately ten (10) feet in length extending from the off course side of the start/finish line.
3. Riding instructions:
 - a. All riders must be in the arena and the gate closed before the first rider begins their run.
 - b. The first rider races down around all flags, picks up the flag farthest from the start/finish line and brings it back across the start/finish line. All riders must cross the start/finish line with their flag or the team will receive a “no time”.
 - c. Once the previous rider is off course, subsequent riders each follow the same action one at a time, each taking the farthest flag in line until all riders have completed the course
 - d. Any flag knocked down must be picked up by the corresponding rider in his own turn. Riders may dismount to accomplish this. A teammates dropped flag may be reset before remounting.
 - e. Riders must be on horseback when they cross the finish line.
4. Contestants will be issued a “NO TIME” when two athletes are determined to be on the course at the same time. The team will receive participation points.
 - a. Two athletes are determined to be on the course at the same time if the nose of the departing horse crosses the start/finish line prior to the hind feet of the return horse crossing the start/finish line - TAILS DO NOT COUNT.
5. Team Canadian Flags is a 4 person team event. If a school has only 3 riding members, they may ride this event with 3 athletes using 4 different equines.

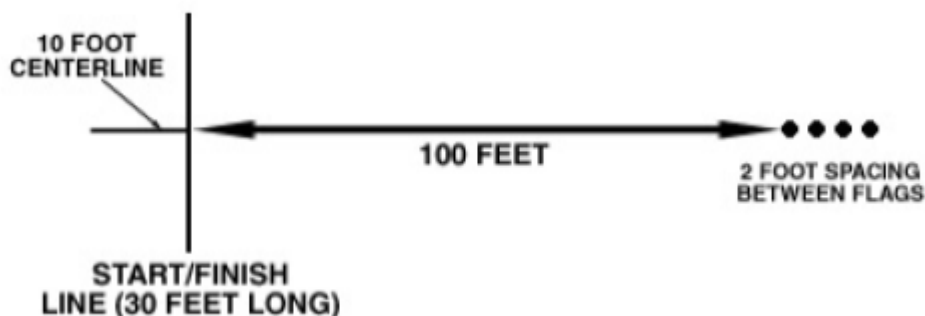

Figure 2-7. Team Canadian Flags Pattern

Drill Events

1. Freestyle Fours - Teams with 4 riders
2. Freestyle +5 - Teams with 5 or more riders
3. There are no required maneuvers.
4. Required equipment
 - a. Drill team may be ridden in English or Western equipment with corresponding attire. All members of a team will use the same style equipment (either English or Western). Equipment should be clean, in good working order and safe.
 - b. Bridles must be worn.
 - c. Arm bands identifying Captain/Co-Captain are optional.
5. A two minute warm up in the competition arena will be offered to each team directly prior to their official competition performance
 - a. Teams that fail to exit the arena before their two-minute warm up time has ended will receive a penalty deduction of 10 points for each full or partial portion of 30 seconds they are over time.
6. Timing
 - a. An official timer will be stationed at the gate entrance to allow for time to begin when the first horse's nose breaks the plain of the gate and the time to end when the last horse's hind legs have crossed the same plain of the gate. Tail does count.
7. PNWIC score sheet will be used that reflects no required maneuvers.
8. General drill rules:
 - a. Athletes can only compete in one (1) drill (either working fours or 5+ program) for any team at each competition.
 - b. Position in the show schedule will be determined by the show chairman or committee.
 - c. There is a time limit of 4 to 6 minutes per team to perform a drill.
 - d. All equines will be serviceably sound and in good condition. Any equines showing signs of lameness or unsoundness will not be allowed to compete.
 - e. Drill team coaches or other athletes will not be allowed in the arena while their team is competing. Coaching or encouraging from outside the arena is permissible.
 - f. During drill competition, only equines involved in the performance will be allowed in the arena.
 - g. It is mandatory to offer a drill practice period in the competition arena prior to the actual run. During the assigned practice period, only the equine in the drill activity will be allowed in the arena.
 - h. During practice only coaching staff will be allowed in the arena on foot, all other athletes must be mounted.
 - i. Times for length of each drill performance will be recorded on the official scorecard.

- j. Time scores are to be taken by official timers and reported to the judges.
- k. Etiquette Standard for the use of Stars and Stripes per Public Law 94.344 use of the United States Flag: The flag should never be carried flat or horizontal, but always aloft and free.
 - i. The U.S. flag should not be dipped to any person or thing. Regimental colors, state, city, organizational or other flags are dipped as a mark of honor.
 - ii. Do not let the Flag of the United States touch anything beneath it, such as the ground, floor, water or merchandise.

Freestyle Program (5 or more)

1. Shall consist of no less than five athletes

Freestyle Working Fours

1. Shall consist of no less than four athletes

Drill Team Judging Guidelines

1. Guidelines may overlap Judges discretion.
2. EXECUTION OF DRILL
 - a. Alignment/Accuracy: Vertical and horizontal alignment in maneuvers of a team. Lines should always be straight whether in squads, columns, company front etc. Alignment also pertains to placement of the maneuver in the arena.
 - b. Spacing: Maintaining a uniform distance between all equines throughout an entire maneuver. Distance may be varied as long as it is equal.
 - c. Timing/Coordination: How athletes work together in the performance of their maneuvers. There are no missed holes, collisions, etc.. A team should move as a unit and be smooth in its maneuvers. This includes the ability of the team to foresee the necessity to adjust it's speed to the maneuver without breaking gait. Both spacing and gait are to be maintained. The team will be penalized for loss of gait unless change of pace is obviously a part of the maneuver.
 - d. Degree of Difficulty: Consistency and accuracy of identifiable maneuvers; taking into account overall balance of presentation, transitions and pace at which they are executed. Degree of Difficulty can also be influenced by the correct carriage of flags or pennants.

Drill Design

1. ORIGINALITY/UNIQUENESS: Patterns or methods of presentation, attractiveness of pattern, symmetry and definition of maneuvers; also the attractiveness of method used to show continuity in which one maneuver leads to another. A team performing a variety of different type maneuvers. The patterns should not be all circles or all lines. A team moving from one maneuver to another without repeating should receive credit for variety.
2. "SPECTACULARITY"/CROWD APPEAL: Refers to the execution of maneuvers. Teams should be alert, wide-awake and at attention at all times. Speed should be noted because it is more difficult to do a maneuver well when it is done at a faster speed. It is also more difficult to do some diagrammatically simple maneuvers well. Precision should not be sacrificed for speed. Speed is to be used only as an added point for "spectacularity/crowd appeal-pleasing to an audience.

General Impression

1. **UNIFORMITY/EQUINE & EQUIPMENT:** Shall be of like style. Multiple colors of uniform and equipment are allowed. Saddles, bits, bridles and use of tie downs are not required to be identical within a team. Breast collar, saddle pad covers, girth cover, leg bands, flag/pennant and poles should be uniform.
2. **EQUINE MANNERS/PERFORMANCE:** Equines are expected to be responsive, quiet and obedient. Faults include broken gaits (jogging during the loping phase or loping during the trotting phase), disobedient (blowup, fit), striking or biting. Pinning ears or active tail should not be judged for equine manners. Manners are ways of going and suitability as a drill equine. Equines should be well behaved. They should not jump or shy and should work freely and easily at all times. They should stand quietly and straight in line and not move until the signal is given.
3. **HORSEMANSHIP:** Good equitation/horsemanship with balanced seat shall be emphasized. Two hands are permitted on the reins for English or Western, one hand is preferred but not required. Ridden correctly one hand should sore higher than two handed. There should be light contact without undue restraint on the reins; proper use of hands and legs shall be evaluated. Degree of horsemanship is evaluated to determine quality of horsemanship. Flag presentation shall include manner in which the flags are carried. The shafts shall be perpendicular with forearm parallel to the ground. Elbows should be fixed at a right angle; the emblem should be pointed forward. Flags should be kept free and not allowed to wind around the pole.
4. **Explanation of Deductions – Deduction point amounts are on Freestyle Drill Score Sheet**
 - a. **BROKEN OR DROPPED EQUIPMENT, TACK OR UNIFORMS:** Shall include helmets, leg bands, pennants, flags, tail bows or anything that has fallen to the ground or broken. The Judge, Captain/Co-Captain (when present) or Coach can call time if the broken or dropped equipment necessitates it. Time will stop and start on Judge, Captain/Co-Captain (when present) or Coach's signal.
 - b. **COLLISION NO FALL OF EQUINE OR RIDER:** Shall be deemed to be any physical contact between two or more equines, two or more athletes, or equine and athlete with a wall or gate which does not result in a fall (Only the Judge, Captain/Co-Captain(when present) or Coach can call time. Time will stop and start on Judge or Captain/Co-Captain/(when present) or Coach signal).
 - c. **EXCESSIVE/UNCONTROLLED SPEED:** Riders will be considered to have excessive/uncontrolled speed if the athlete loses control or a severe loss of precision due to speed..
 - d. **FALL OF EQUINE AND/OR ATHLETE:** No collision involved. A team will be able to halt and restart as soon as equine and athlete are in position. Same rules for restart as fall due to collision. If an athlete that is carrying a flag, only the fall of equine and or athlete will be deducted, not the dropped flag. (Only the Judge, Captain/Co-Captain/ (when present) or Coach can call time. Time will stop and start on Judge, Captain/Co-Captain (when present) or Coach's signal.

- e. FALL DUE TO COLLISION: Shall be deemed any physical contact between two or more equines, two or more athletes, or equine and athlete with a wall or gate, which results in a fall. If an equine or athlete is unable to continue, a substitute equine and/or athlete will be allowed to fill the position. The position may remain empty. Only the Judge, Captain/Co-Captain (when present) or Coach can call time. Time will stop and start on Judge, Captain/Co-Captain (when present) or Coach's signal.
 - f. REGROUP May be done when a team has lost its organization and or athletes must change position to be able to continue or other extenuating circumstances such as severe tack breakage, fall of equines and or athlete, or medical emergency. If a team is unable to continue, they may ask the senior judge for permission to leave the arena and return at the end of the draw. Time and deductions will remain official; timekeeper will record time when performance is stopped by Captain/Co-Captain (when present) or Coach and start time when Captain/Co-Captain (when present) or Coach's signals to commence the performance.
 - g. TIME (4 to 6 minutes): Timing starts when the first horse's nose passes through the entry gate and/or cones marking entrance and stops when the last horse's hind legs have crossed the exit gate and/or cones. An official timekeeper will enforce this rule. Only the Captain/Co-Captain (when present) Coach can call time. Time will stop and start on Captain/Co-Captain (when present) or Coach's signal.
5. DISQUALIFICATION: Unsportsmanlike conduct, in addition to the disqualification reasons listed in the General Information section of this manual, will result in disqualification of the drill team. Drill shall be scored with all deductions that may apply.
6. ALTERNATE GUIDELINES:
- a. In Working Fours and Five+ drill teams, the number of alternates is unlimited.
 - b. In Drill, riding short is allowed upon approval by the PNWIC committee.