

2023 USEF FIRST LEVEL TEST 1

PURPOSE

To confirm that the horse demonstrates correct basics, and in addition to the requirements of Training Level, has developed improved balance, lateral suppleness and throughness, as well as the thrust to perform lengthenings of stride. The horse should be on the bit.

All trot work may be ridden sitting or rising, unless otherwise stated.

READER PLEASE NOTE: Anything in parentheses should not be read.

INTRODUCE

10m half circle at trot;
15m circle in canter;
lengthening of stride in trot

ENTRY NO:

Conditions:

ARENA SIZE: Standard
AVERAGE RIDE TIME: 5:30
(from entry at A to final halt)
Suggested to add at least 2 min. for scheduling purposes

MAXIMUM PTS: 270

| TEST | | DIRECTIVES | POINTS | COEF | TOTAL | REMARKS |
|------|--------------------|---|--|------|-------|---------|
| 1. | A X | Enter working trot Halt, salute Proceed working trot | Regularity and quality of trot; willing, clear transitions; straightness; attentiveness; immobility (min. 3 seconds) | | | |
| 2. | C E-X | Track left Half circle left 10m, returning to track at H | Regularity and quality of trot; shape and size of half circle; bend; balance; straightness | | | |
| 3. | B-X | Half circle right 10m, returning to track at M | Regularity and quality of trot; shape and size of half circle; bend; balance; straightness | | | |
| 4. | C Before C C | Circle left 20m in rising trot, allowing the horse to stretch forward and downward while maintaining contact Shorten the reins Working trot | Forward and downward stretch over the back into a light contact, maintaining balance and quality of trot; bend; shape and size of circle; willing, clear transitions | 2 | | |
| 5. | H-P P | Change rein, lengthen stride in trot Working trot | Moderate lengthening of frame and stride; regularity and quality of trot; straightness; consistent tempo; willing, clear transitions; bend and balance in corner | | | |
| 6. | A | Medium walk | Willing, clear transition; regularity, quality, overtrack; bend and balance in corner; straightness | 2 | | |
| 7. | V-R R | Change rein, free walk Medium walk | Regularity and quality of walks; reach and ground cover with overtrack of free walk allowing complete freedom to stretch the neck forward and downward; straightness; willing, clear transitions | 2 | | |
| 8. | M C | Working trot Working canter left lead | Willing, clear transitions; regularity and quality of gaits; bend and balance in corners | 2 | | |
| 9. | E | Circle left 15m | Regularity and quality of canter; shape and size of circle; bend; balance | | | |
| 10. | F-X-H X | Change rein Working trot | Willing, clear transition; regularity and quality of gaits; straightness; bend and balance in corner | | | |
| 11. | C | Working canter right lead | Willing, clear transition; regularity and quality of canter; bend and balance in corner | 2 | | |
| 12. | B | Circle right 15m | Regularity and quality of canter; shape and size of circle; bend; balance | | | |
| 13. | A | Working trot | Willing, clear transition; regularity and quality of trot; straightness; bend and balance in corner | | | |
| 14. | K-R R | Change rein, lengthen stride in trot Working trot | Moderate lengthening of frame and stride; regularity and quality of trot; straightness; consistent tempo; willing, clear transitions; bend and balance in corners | | | |
| 15. | E X G | Half circle left 10m Down centerline Halt, salute | Bend and balance in half circle; regularity and quality of trot; willing, clear transition; straightness; attentiveness; immobility (min. 3 seconds) | | | |

Leave arena at A in free walk.

2023 USEF FIRST LEVEL TEST 1

| COLLECTIVE MARKS | | | |
|---|--|--|--|
| GAITS (Freedom and regularity) | | 1 | |
| IMPULSION (Desire to move forward; elasticity of the steps; suppleness of the back; engagement of the hindquarters) | | 2 | |
| SUBMISSION (Willing cooperation; harmony; attention and confidence; acceptance of bit and aids; straightness; lightness of forehand and ease of movements) | | 2 | |
| RIDER'S POSITION AND SEAT (Alignment; posture; stability; weight placement; following mechanics of the gaits) | | 1 | |
| RIDER'S CORRECT AND EFFECTIVE USE OF AIDS (Clarity; subtlety; independence; accuracy of test) | | 1 | |
| FURTHER REMARKS: | | | |
| To be deducted Errors of the course and omissions are penalized | | 1st Time = 2 points 2nd Time = 4 points 3rd Time = Elimination | |
| | | SUBTOTAL: | |
| | | ERRORS: (-) | |
| | | TOTAL POINTS: (Max Points: 270) | |

| | |
|---|--------------------------|
| United States Equestrian Federation, Inc. 2023 USEF FIRST LEVEL TEST 1 | |
| _____ | Name of Competition |
| _____ | Date of Competition |
| _____ | Name and Number of Horse |
| _____ | Name of Rider |
| Final Score Maximum Pts: 270 | |
| _____ | Points |
| _____ | Percent |
| _____ | Name of Judge |
| _____ | Signature of Judge |

| Date: _____ | | State: _____ | | District: _____ | |
|---|---|--------------|------------------|-----------------|--|
| <u>CLASS: DRIVING #1</u> | | | | | |
| HIGH SCHOOL: _____ | | | ATHLETE #: _____ | | |
| # | ELEMENT JUDGED: | COMMENTS: | SCORE | | |
| 1. | Be ready at serpentine. Pick up working trot and serpentine cones as diagrammed. Turn onto center line. | | | | |
| 2. | Collect to slow/jog trot and travel straight through cone box | | | | |
| 3. | Loop around cone labeled 1. | | | | |
| 4. | Continue jog trot and loop around cone labeled 2, then out of cone box and turn right along short wall and turn right onto long wall. | | | | |
| 5. | Transition to walk and walk straight ahead. Turn onto diagonal line | | | | |
| 6. | Once on diagonal line transition to strong trot and continue strong trot across diagonal line. | | | | |
| 7. | Halt and allow horse to settle | | | | |
| 8. | Back 4-6 Steps | | | | |
| 9. | Perform approximately a 270* left wheel pivot and wait to be excused. Once Excused walk out of arena | | | | |
| 10. | Overall Reinsmanship | | | | |
| Judge's Signature: _____ | | | | | |
| <p>Expectations:</p> <ul style="list-style-type: none"> • Walk – A free, flat-footed, regular and unconstrained walk of moderate extension <i>is required</i>. The equine should walk energetically, but calmly, with an even and determined pace. • Slow Trot/Jog: The equine should maintain impulsion while showing submission to the bit. • Working Trot: This is a pace between the strong and slow trot. The equine should go forward freely and straight; on a taut, but light rein. • Strong or Extended Trot: This is a clear, but not excessive, increase in pace and lengthening of stride while remaining well balanced. Light contact to be maintained. Excessive speed will be penalized. <p>Grooming and clean equipment will be noted and will be considered in the Overall Reinsmanship scoring. The course is set for standard, draft or mini equines. Use and plan arena space appropriately. The pivot should be steady continual motion with little or no movement in the pivot wheel.</p> <p>All athletes will be subject to an equipment check prior to competing. If equipment, animal, or athlete is deemed unsafe they will be excused and NOT allowed to compete.</p> | | | | | |

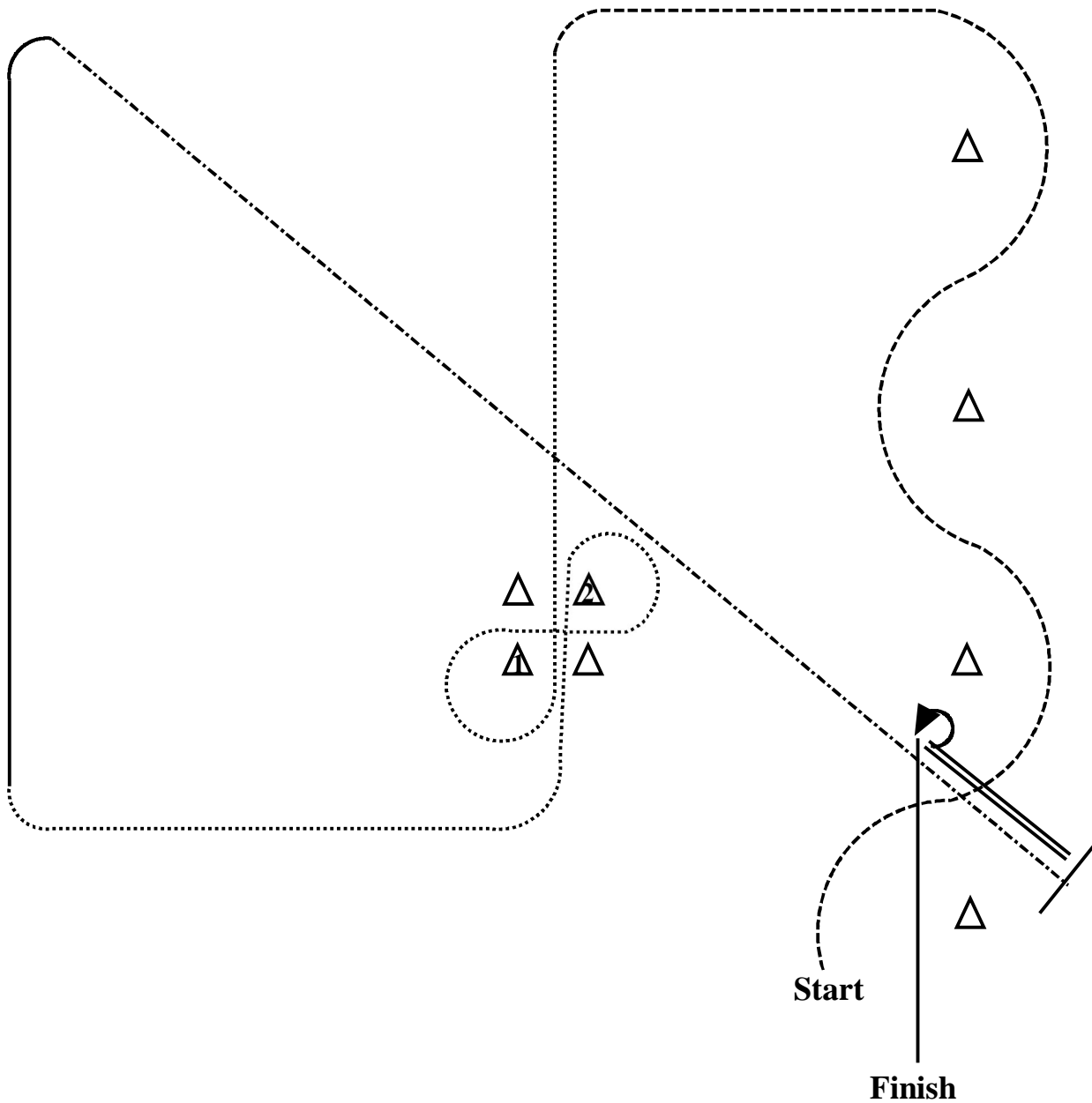

PNWIC
 Driving #1
 Revised 5.29.14

| Legend: | |
|--------------|-----------|
| Walk | _____ |
| Slow Trot | |
| Working Trot | ----- |
| Strong Trot | - - - - - |
| Back | ===== |

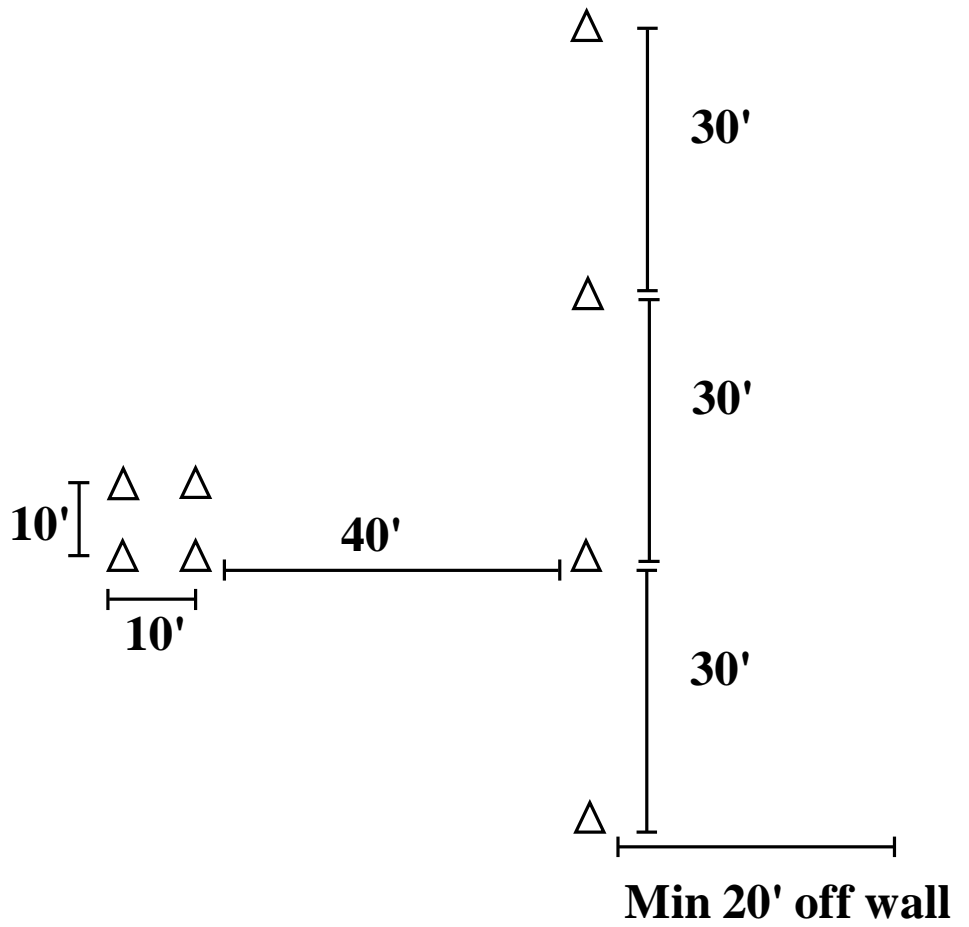

PNWIC
Driving
Dimensions #1
 Revised 5.21.14

| Legend: | |
|---------------------|----------|
| Walk | _____ |
| Slow Trot | |
| Working Trot | ----- |
| Strong Trot | ----- |
| Back | XXXXXXXX |

Date: _____

District: _____

CLASS: HUNT SEAT EQUITATION OVER FENCES #1

HIGH SCHOOL: _____

ATHLETE #: _____

| # | ELEMENT JUDGED: | COMMENTS: | Score |
|-----|--|-----------|-------|
| 1. | Setup and approach 1st fence, Post and Rail | | |
| 2. | 2nd Fence (a&b) Post and Rail | | |
| 3. | 3rd Fence, Gate/Fence | | |
| 4. | 4th Fence, Oxer | | |
| 5. | 5th Fence, Oxer | | |
| 6. | 6th Fence, ¼ Round | | |
| 7. | 7th Fence, Post and Rail | | |
| 8. | Halt before end of arena. Back 3 steps. Wait to be excused. Exit at sitting trot | | |
| 9. | Rider Equitation | | |
| 10. | Overall Horsemanship | | |
| 11. | REFUSALS: Deduct 3 points for 1st refusal, 5 points for 2nd refusal, elimination after 3rd refusal | | |

Judge's Signature: _____

Expectations:

- Athlete should have a workmanlike appearance, seat and hands being light and supple, conveying the impression of complete control.
- Hands should be above and in front of equine's withers, thumbs thirty degrees inside the vertical, hands slightly apart and making a straight line from equine's mouth to athlete's elbow. Reins may be held to inside or outside of little finger. Bight of reins may fall on either side. Athlete should keep light and consistent contact with equine's mouth.
- In basic position the eyes should be up and looking toward the next fence. Toes should be at an angle best suited to the athlete's conformation. Ankles should be flexible, heels down, calf of leg in contact with equine and slightly behind the girth. Iron should be on the ball of the foot and must not be tied to the girth.
- At slower gaits there should be a near-straight line from the athlete's shoulder, through the hip, down to the heel. The shoulders should be a couple of degrees in front of the vertical at a Canter, Hand Gallop, and when jumping.
- The course is expected to be ridden at a canter.
- At the Judge's discretion, an eliminated athlete may jump an additional fence, but may not continue thereafter.
- Riders will be judged on their lines of approach to fences, striding, and proper leads. Breaking gait on course is a fault (except when called for). Lead changes should be done over the fence or as a flying change before entering turns.
- After the tack inspection, athletes will take the course and judging will immediately begin. This will include judging the preparation circle.

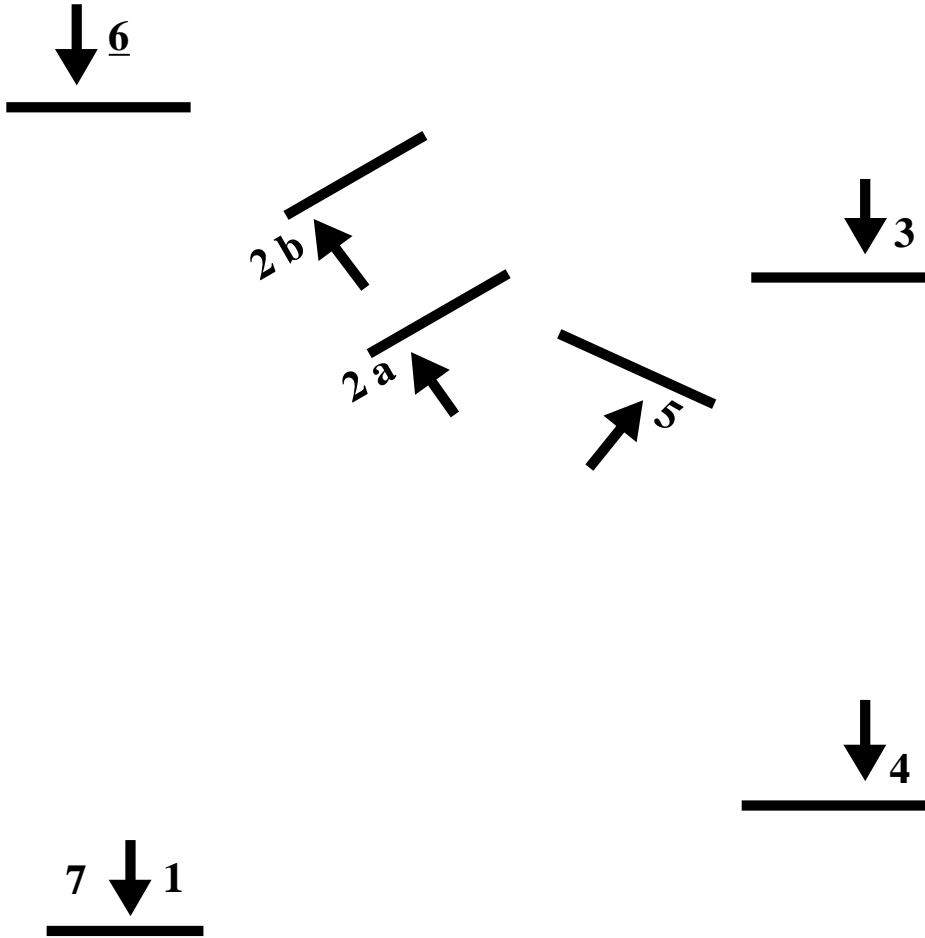

Gate

Note: There will be no qualifying fences. Once the athlete has had their tack safety inspection, and is in the arena, they will take the course and judging will begin. A circle before beginning is still acceptable.

| |
|---|
| <p style="text-align: center;">PNWIC</p> <p style="text-align: center;">Hunt Seat Equitation Over Fences #1</p> <p style="text-align: right;">Revised 5.21.14</p> |
|---|

- 1&7: Post and rail 2'6"**
- 2a: Post and rail 2'6"-2'9"**
- 2b: Post and rail 2'6"-2'9"**
- 3: Gate/Fence with optional top rail 2'6"-2'9"**
- 4: Oxer 2'6"-2'9"**
- 5: Oxer 2'6"-2'9"**
- 6: 1/4 round with optional top rail 2'6"-2'9"**

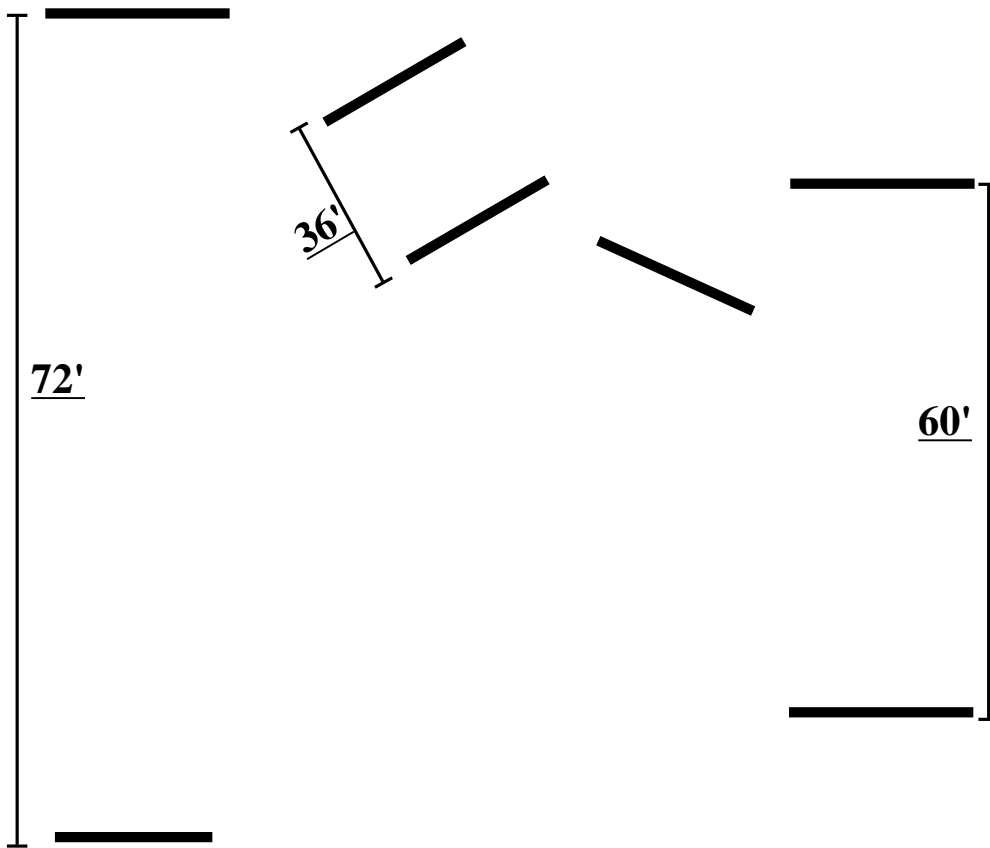

Gate

Note: There will be no qualifying fences. Once the athlete has had their tack safety inspection, and is in the arena, they will take the course and judging will begin. A circle before beginning is still acceptable.

| |
|---|
| <p>PNWIC</p> <p>Hunt Seat Equitation Over Fences #1</p> <p>Revised 5.21.14</p> |
|---|

- 1&7: Post and rail 2'6"**
- 2a: Post and rail 2'6"-2'9"**
- 2b: Post and rail 2'6"-2'9"**
- 3: Gate/Fence with optional top rail 2'6"-2'9"**
- 4: Oxer 2'6"-2'9"**
- 5: Oxer 2'6"-2'9"**
- 6: 1/4 round with optional top rail 2'6"-2'9"**

Date: _____

State: _____

District: _____

CLASS: HUNT SEAT EQUITATION #1

HIGH SCHOOL: _____

ATHLETE #: _____

| # | ELEMENT JUDGED: | COMMENTS: | Score |
|-----|---|-----------|-------|
| 1. | Wait for judge to acknowledge rider. Pick up Right lead canter | | |
| 2. | Change leads (Simple or Flying only) | | |
| 3. | After lead change transition to hand gallop and continue around end and onto centerline. | | |
| 4. | Transition to posting trot and drop irons (while trotting) | | |
| 5. | Circle at posting trot to left without irons. | | |
| 6. | Circle at posting trot to right without irons. Pick up irons in last 1/3 or circle while continuing trot. | | |
| 7. | Pick up right lead, turn right, and continue down long wall. | | |
| 8. | Before corner, transition to sitting trot, and turn onto diagonal line. | | |
| 9. | Extend trot across diagonal line | | |
| 10. | Halt, perform 360* right forehand turn | | |
| 11. | Back 6 steps or so. Settle, wait to be excused. | | |
| 12. | Overall Horsemanship | | |
| 13. | Rider Equitation-Seat, hands, legs. | | |

Judge's Signature: _____

Expectations:

- Light contact from hands to bit through reins is expected at all times. Elbows should be in a straight line formed from elbow through hands to bit. Hands form an "A" while keeping wrists straight.
- Consistent cadence, rhythm, and impulsion are expected throughout.
- Should be ridden as a flat class in preparation for over fences. Rider should maintain chin up, heels down, and leg contact with horse's barrel at all times.
- Little fingers may be either inside or outside of reins.
- Eyes should be kept up, looking toward next maneuver.
- Iron should remain on ball of foot throughout pattern (Except when asked to drop irons).
- At walk & trot, there should be a near straight line from the shoulder to the hip, to the heel.
- At canter and hand gallop, shoulders should be a couple of degrees in front of the vertical.
- Right diagonal means side to post on, not correct diagonal
- Lead changes should be smooth with quality flying lead changes receiving higher scores.

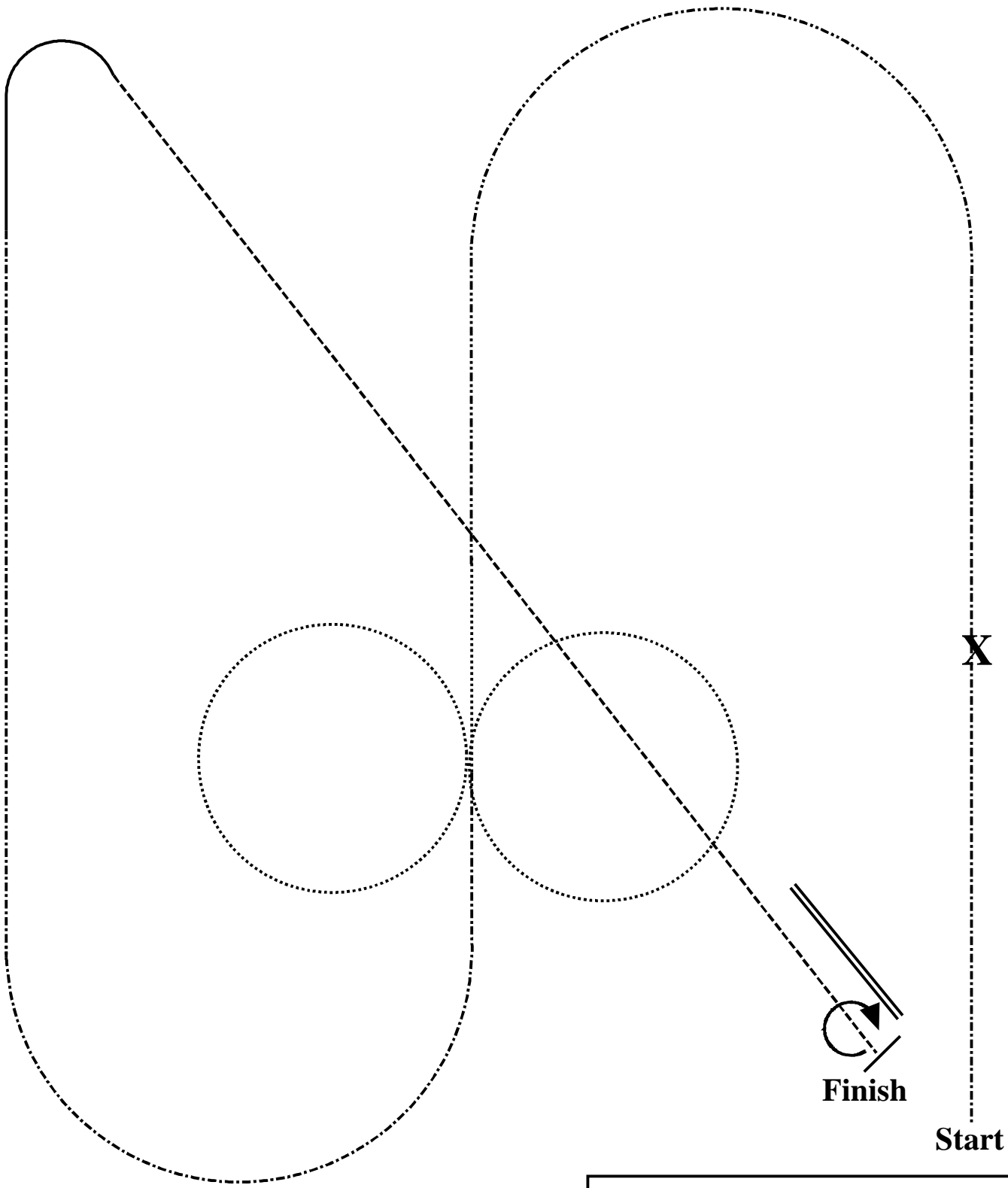

PNWIC
Hunt Seat Equitation #1

Revised 5.21.14

| Legend: | |
|---------------|-------|
| Sitting Trot | _____ |
| Posting Trot | |
| Extended Trot | ----- |
| Canter | ----- |
| Hand Gallop | ----- |
| Back | ===== |

| | | | | |
|--|------------|----------------------|---------------------------|------------|
| Date: _____ State: _____ District: _____ | | | | |
| CLASS: IN-HAND OBSTACLE RELAY #1 | | | | |
| HIGH SCHOOL: _____ | | TEAM: _____ | | |
| Obstacle: | Athlete #: | Athlete #: | Athlete #: | Athlete #: |
| Trot over raised pole and circle cone to right. | | | | |
| Halt. Perform 540* Right Haunch | | | | |
| Back through "U-Shaped" Chute, | | | | |
| Position for sidepass, sidepass left. Walk over bridge with raised pole and guardrails. | | | | |
| Optional: Perform a 360* Right turn (not haunch or pivot, just tight turn) in box | | | | |
| Penalty Points | - | - | - | - |
| Total points / handler minus penalty points | | | | |
| Total of Individual Handler Scores | | | | |
| Overall Handling & Horsemanship – Including while waiting behind the start line. (10 points possible) | | | | |
| Subtotal | | | | |
| Total Time: _____ | | Time Penalty Points: | | - |
| | | | Total Team Points: | |
| Judge's Signature: _____ | | | | |

Expectations:

- This is a horsemanship class! Equine and athletes should be properly groomed as in a Showmanship class.
- Maneuvers should be crisp and practiced. Equine should show no resistance to handler during any maneuver and should appear as if not on a lead rope.
- Equine should move quickly, but maintain the superior ground manners that one would expect in a showmanship class.
- Handlers will receive scratch penalties for each time there are two handlers on course at the same time. This includes crossing the line accidentally while switching sides of the horse behind the line. Scratch penalties will also be incurred if a horse on course inadvertently crosses the start/finish line while still competing.
- Exhibitors and equines must enter and exit the course on the inside of the start finish poles. If athlete and/or equine crosses outside of the poles, the team will receive a No Time and only be eligible for participation points.
- All obstacles should be done by both horse and handler except where specifically noted. The handler may be on inside or outside of the optional obstacle, and the handler does not need to be inside or follow the same path as the horse for obstacle #3.

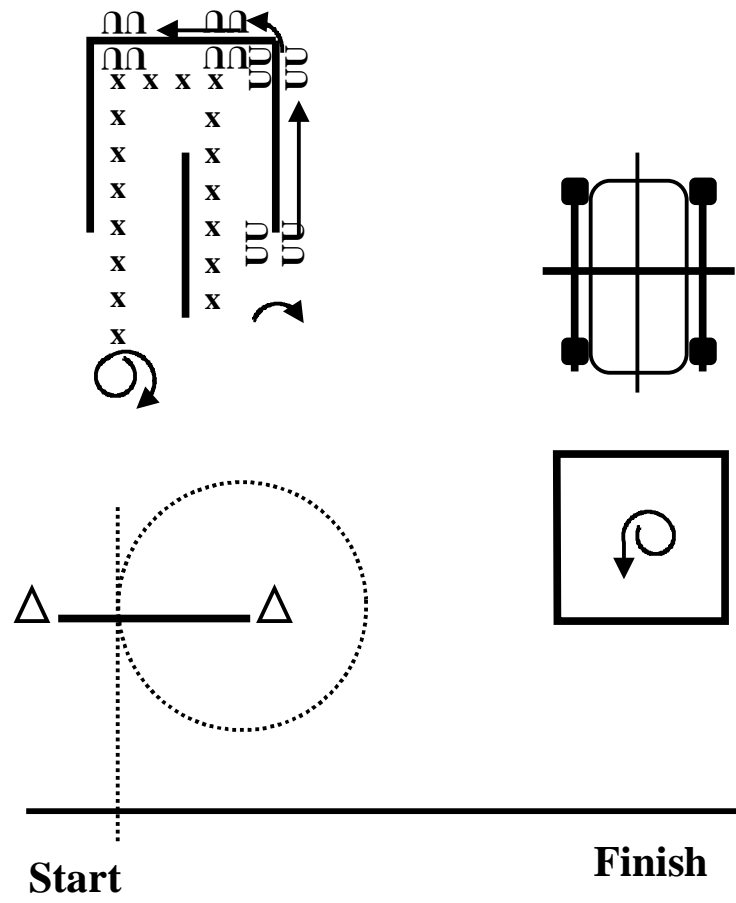

PNWIC
In Hand Obstacle Relay #1
 (I.H.O.R.)

Revised 5.29.14

| Legend: | |
|-----------------|------------|
| Walk | ————— |
| Jog/Trot | |
| Back | XXXXXXXXXX |

Start by measuring the 30' start line

From the left pole measure up 10' and place cone then 8' pole and then cone

From right end of pole measure up 19' and place 8' pole and build remainder of chute

From bottom of right 10' pole of chute measure 11' to right and set bridge. Set guard rails and pole with risers

Go back to first pole set with cone. Using right cone measure 12' to right and set bottom left corner of box.

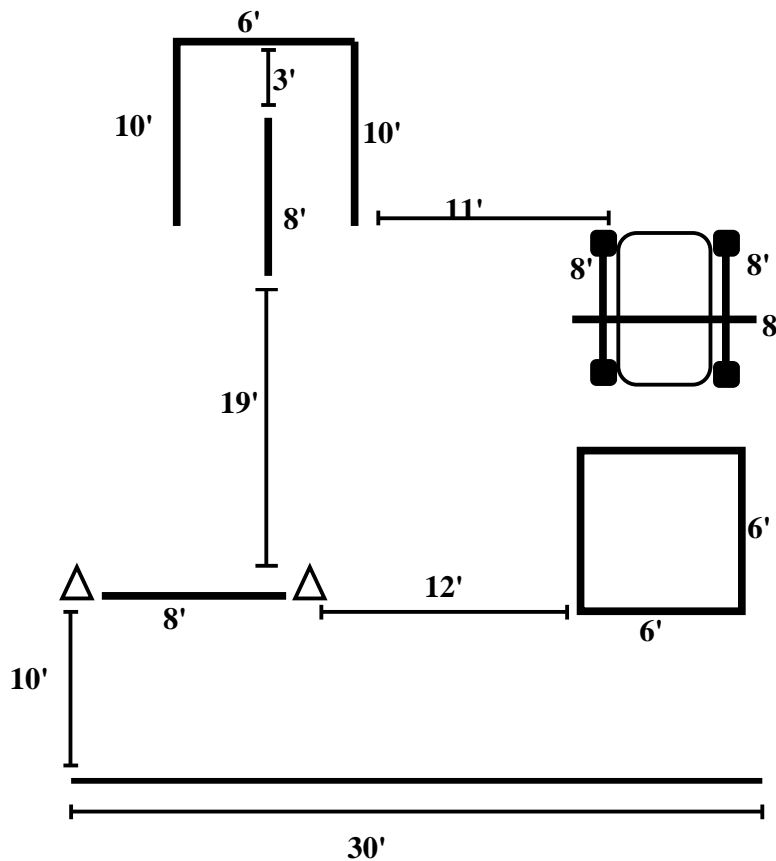

PNWIC

In Hand Obstacle Relay #1
(I.H.O.R.)

Revised 5.29.14

Equipment Needed:

- (2) 10' poles
- (5) 8' poles
- (5) 6' poles
- (4) Jump standards
- (2) Cones
- (2) Risers to raise pole from ground above bridge 8"-12" inches
- (2) Gaming Poles (start poles)

| Date: _____ | | State: _____ | District: _____ |
|--|---|------------------|-----------------|
| CLASS: <u>IN-HAND TRAIL #1</u> | | | |
| HIGH SCHOOL: _____ | | ATHLETE #: _____ | |
| # | ELEMENT JUDGED: | COMMENTS: | SCORE |
| 1. | Be ready at gate for right hand push rope gate. Perform gate. Return to near side, position for trot. | | |
| 2. | Transition to jog, jog through chute. Perform serpentine as diagrammed. | | |
| 3. | Sidepass left, re-position. | | |
| 4. | Sidepass right, position for back. | | |
| 5. | Back from one side of chute to other through center as diagrammed. | | |
| 6. | Trot out of chute over pole and through triangle. | | |
| 7. | Circle cone to right. | | |
| 8. | Halt. Change sides. Circle cone and trot over poles to left. Halt, Change return to near side. Trot straight ahead. | | |
| 9. | Transition to walk. Walk over short side of bridge, turn, walk over long side of bridge, then over raised poles. | | |
| 10. | Perform a tight turn to right in box (not haunch or forehand). | | |
| 11. | Walk out of box. Halt. Present. Wait to be excused. | | |
| 12. | Overall Horsemanship | | |
| Judge's Signature: _____ | | | |
| Expectations: | | | |
| <ul style="list-style-type: none"> • Athlete and equine should create a working team. Movement through and over obstacles should be crisp while allowing the equine to negotiate each step. Accuracy, smoothness and acceptance of obstacles should be points of training. Timing will count. • Handlers should perform all obstacles with horse unless specifically noted. The handler may be on the inside or outside of the box while the horse performs the turn inside the box. • Haunch turns, pivots, lateral movement and backing should be correct and smooth with continual movement. • Refusals will deduct points. After 2 attempts, athletes will be asked to move on. A refusal is any unnecessary and unintentional movement not aiding in completion of the maneuver. The following two examples would be considered refusals. A horse taking a step backwards while approaching a bridge without being asked to do so by its rider. A horse taking a step forward while attempting to complete a back through without being asked to do so by its rider. An unintentional complete stop of movement while approaching or completing an obstacle will also be considered a refusal. • It should appear that the equine is working without the use of a lead rope exhibiting no resistance. Judges will be looking for "finished" equine/athlete team. | | | |

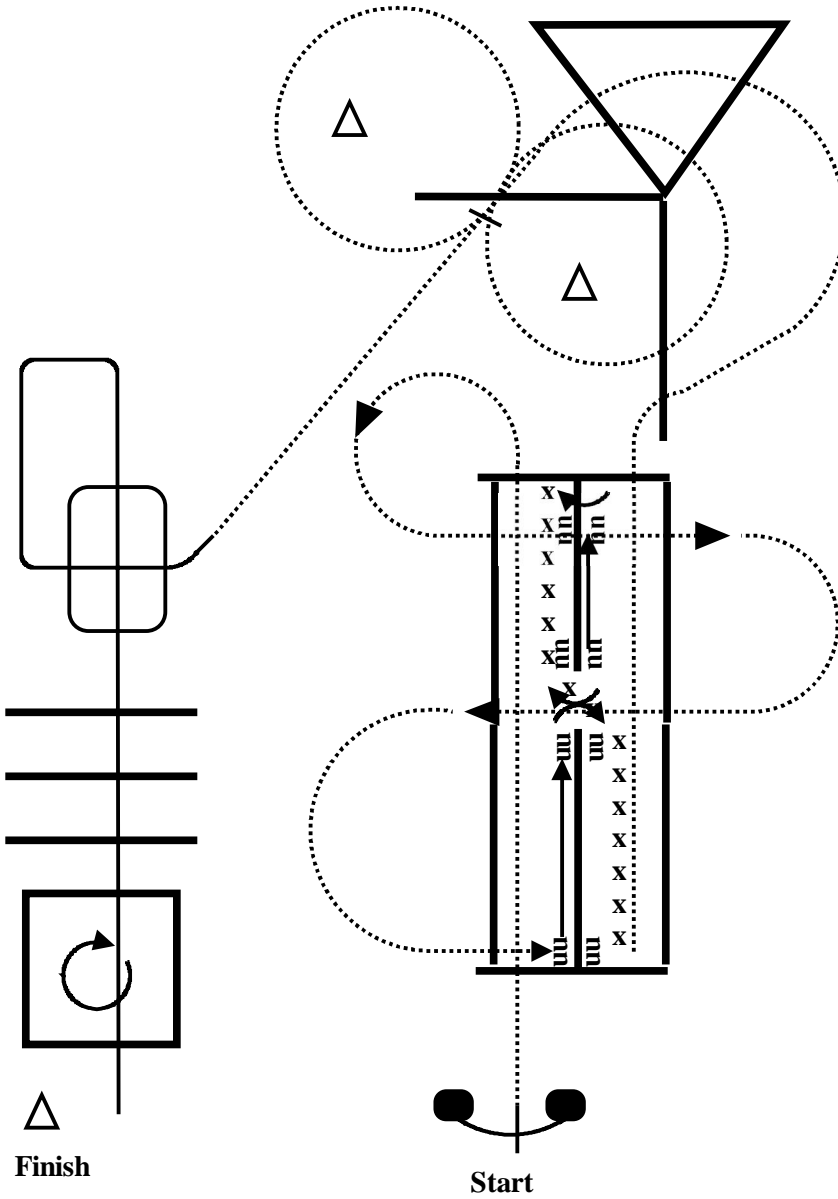
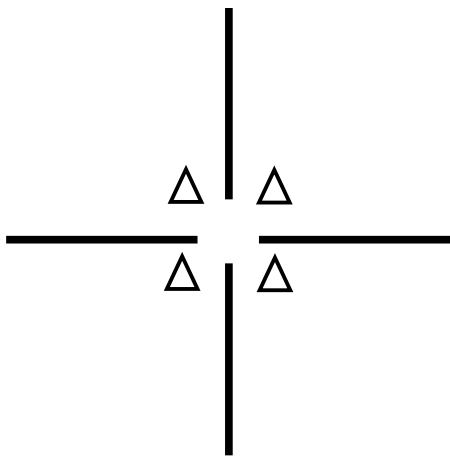

PNWIC
In Hand Trail #1

Revised 5.29.14

| Legend: | |
|-------------|------------|
| Walk | ————— |
| Jog/Trot | |
| Lope/Canter | ----- |
| Back | XXXXXXXXXX |

Begin by placing left standard of rope gate. Needs to be 85-90' from opposite wall and 56' from left wall. Should be at least 25' from right wall. Set gate.
 Measure 10' from left standard to set chute. Build outer wall of chute. When tape is stretched across width of chute lace 8' poles on 3'. Next build poles off of triangle.
 Cones on lope poles should be placed one foot from end of pole.
 After completing lope poles measure down for walkovers first, then measure and set bridge from walkover poles.

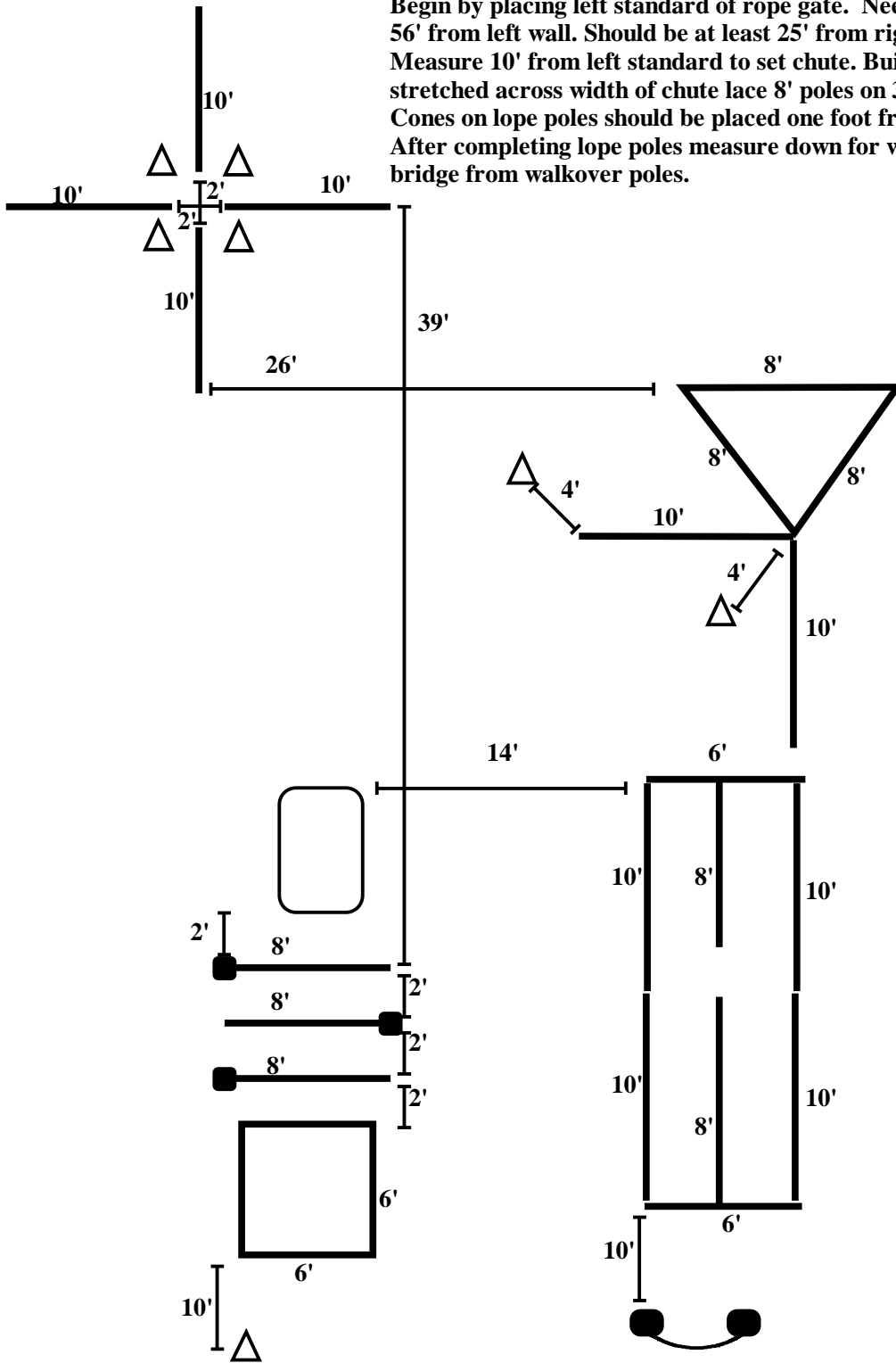

PNWIC
In Hand Trail #1
 Revised 5.29.14

| Equipment Needed: |
|---|
| (10) 10' poles |
| (8) 8' poles |
| (6) 6' poles |
| (7) Standard size cones (about 18" tall) |
| Bridge (min 4' x 6') |
| Rope gate (2 jump standards with rope. Min 4 wide) |
| (3) Risers for walk over poles. (top of pole should be 8"-12" high) |

4/26/2026

PNWIC

Date: _____

District: _____

CLASS: REINING (NRHA Pattern #11)

HIGH SCHOOL: _____

ATHLETE #: _____

| # | ELEMENT JUDGED: | COMMENTS: | Score |
|-----|--|-----------|-------|
| 1. | Complete 4 spins to Left | | |
| 2. | Complete 4 spins to Right | | |
| 3. | Beginning on Right lead , complete 3 circles to the right; the first circle small and slow; the next 2 circles large and fast. | | |
| 4. | Flying lead change at center of arena | | |
| 5. | Complete 3 circles to the left; the first circle small and slow; the next 2 circles large and fast. | | |
| 6. | Flying lead change at center of arena | | |
| 7. | Begin a large circle to the right but do not close the circle, Run down the center of the arena past the end marker and do a Right rollback. | | |
| 8. | Run up the middle to the oposite end of the arena past the end marker and do a Left rollback | | |
| 9. | Run past the center marker and do a sliding stop. Back up to the center of the arena or at least 10 feet. Hesitate to demonstrate the completion of the pattern. | | |
| 10. | Overall Horsemanship. | | |

Judge's Signature: _____

Expectations:

- Horses MUST trot to the center of the arena. This is a required element, but not judged. Points will be deducted from overall horsemanship score for not trotting to center.
- Full use of arena is encouraged as long as the equine is guided by the rider and not the wall.
- There will be a penalty for failure to remain a minimum of 20ft from end of arena when approaching a stop or rollback. Unless it is a direct result of a longer than expected and correct stop.
- Spins shall be balanced on hindquarters and remain in fixed location. Equine is not required to keep a singular pivot foot throughout the maneuver.
- During spins, over or under rotations greater than 90° will result in a "0" for that maneuver. Under or over rotations less than or equal to 90° will be scored based on the quality of the spin.
- Rollback: The rollback begins after the horse is stopped. Horse is allowed to settle briefly after stop. Once motion for rollback has started there must be no hesitation through the lope transition. Lope out of rollback may be on either lead, but horse must be on correct lead prior to corner (with no break in stride) if continuing around end.
- Any off course movements within an element will result in a score of "0" for the entire element.
- Flying lead changes are required and should be attempted. Horses attempting flying changes and not completing will be scored accordingly. Horses not attempting a flying change and performing other changes will be given a score of "0" for that element.
- Sliding stop: Stops are the act of slowing the horse from a lope to a stop position by bringing the hind legs under the horse in a locked position sliding on the hind feet. The horse should enter the stop position by bending the back, bringing the hind legs further under the body while maintaining forward motion and ground contact and cadence with front legs. Throughout the stop, the horse should continue in a straight line while maintaining ground contact with the hind feet.
- Markers will be placed on the wall or fence of the arena at the center of the arena AND at least 50' from each end wall.

Equipment needed: 6 cones**Pattern will take 5-7 minutes.**

Judge

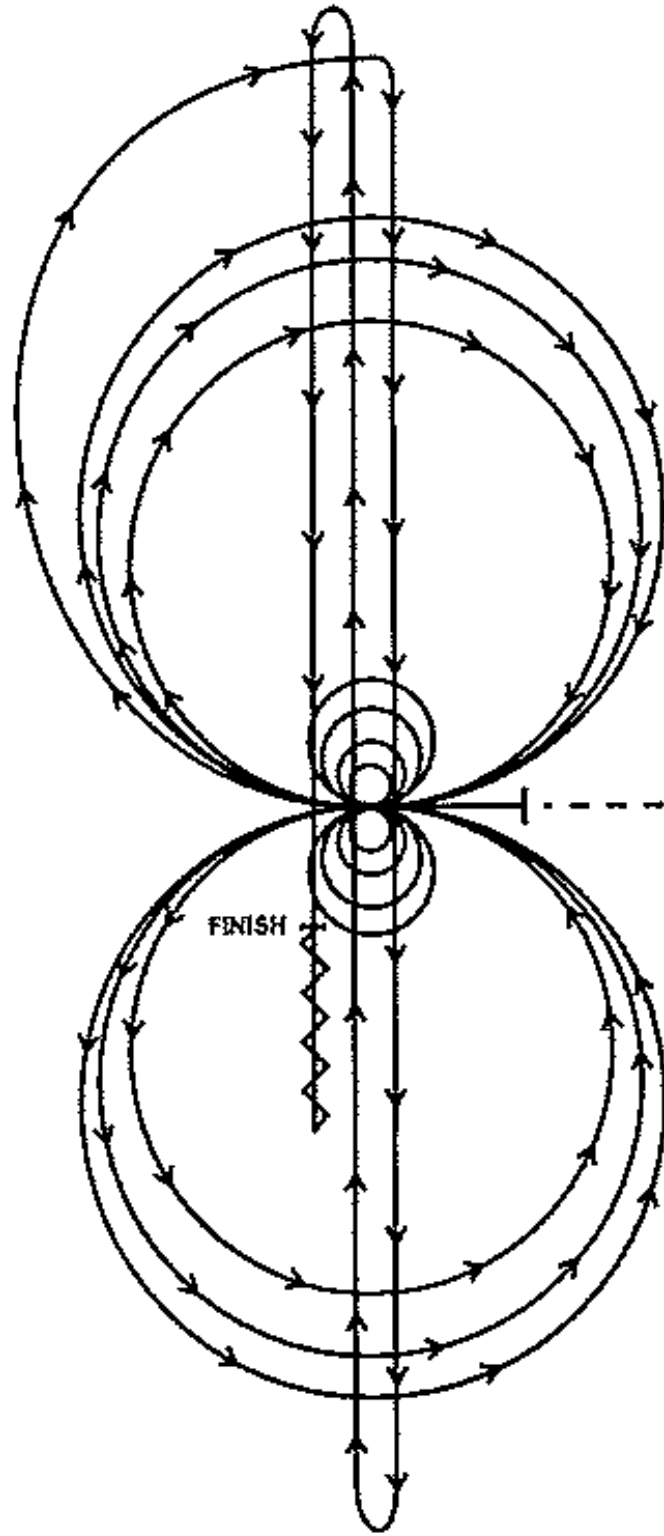

Reining #11
PNWIC
5-10-17

| Date: _____ State: _____ District: _____ | | | |
|---|--|------------------|-------|
| CLASS: <u>SADDLE SEAT EQUITATION #1</u> | | | |
| HIGH SCHOOL: _____ | | ATHLETE #: _____ | |
| # | ELEMENT JUDGED: | COMMENTS: | SCORE |
| 1. | Be ready in start position. Pick up right lead canter along short wall, turning right, and then right into center. | | |
| 2. | Perform circle to right on right lead | | |
| 3. | Change leads | | |
| 4. | Perform circle to left on left lead Continue left lead straight then turn left onto long wall and left onto diagonal line. | | |
| 5. | Once straight on diagonal transition to extended trot. Collect to posting trot through center of diagonal line and then extend again after center. | | |
| 6. | Before corner collect to posting trot and turn left onto short wall and continue until turning left onto next diagonal line. | | |
| 7. | Extend trot across diagonal line. Before corner transition to walk and turn right onto short wall. | | |
| 8. | Pick up Right lead and turn onto center line. Halfway down centerline transition to walk | | |
| 9. | Halt, 360* right forehand turn, back 6 or so steps, settle and wait to be excused. | | |
| 10. | Overall Horsemanship | | |
| 11. | Rider Equitation, Seat, Legs, Hands | | |
| Judge's Signature: _____ | | | |
| Expectations: | | | |
| <ul style="list-style-type: none"> • Proper body and hand position is of utmost importance. An emphasis is placed on appropriate use of reins to properly elevate and present a horse in SaddleSeat frame with a straight line between bit and elbows while using light contact with the equine's mouth. • Body position with ear, shoulder, hip, and heel alignment will be closely observed in this pattern. • Use of the arena to best display the equine's ability and athlete's horsemanship will score higher points. • Animated movement of the equine with no resistance to hand or leg cues during the pattern, maintaining the ability to collect during lead changes and transitions is going to contribute to the overall success of this performance. • Accurate and quality Interrupted lead changes are the expectation and may score 0-10 points | | | |

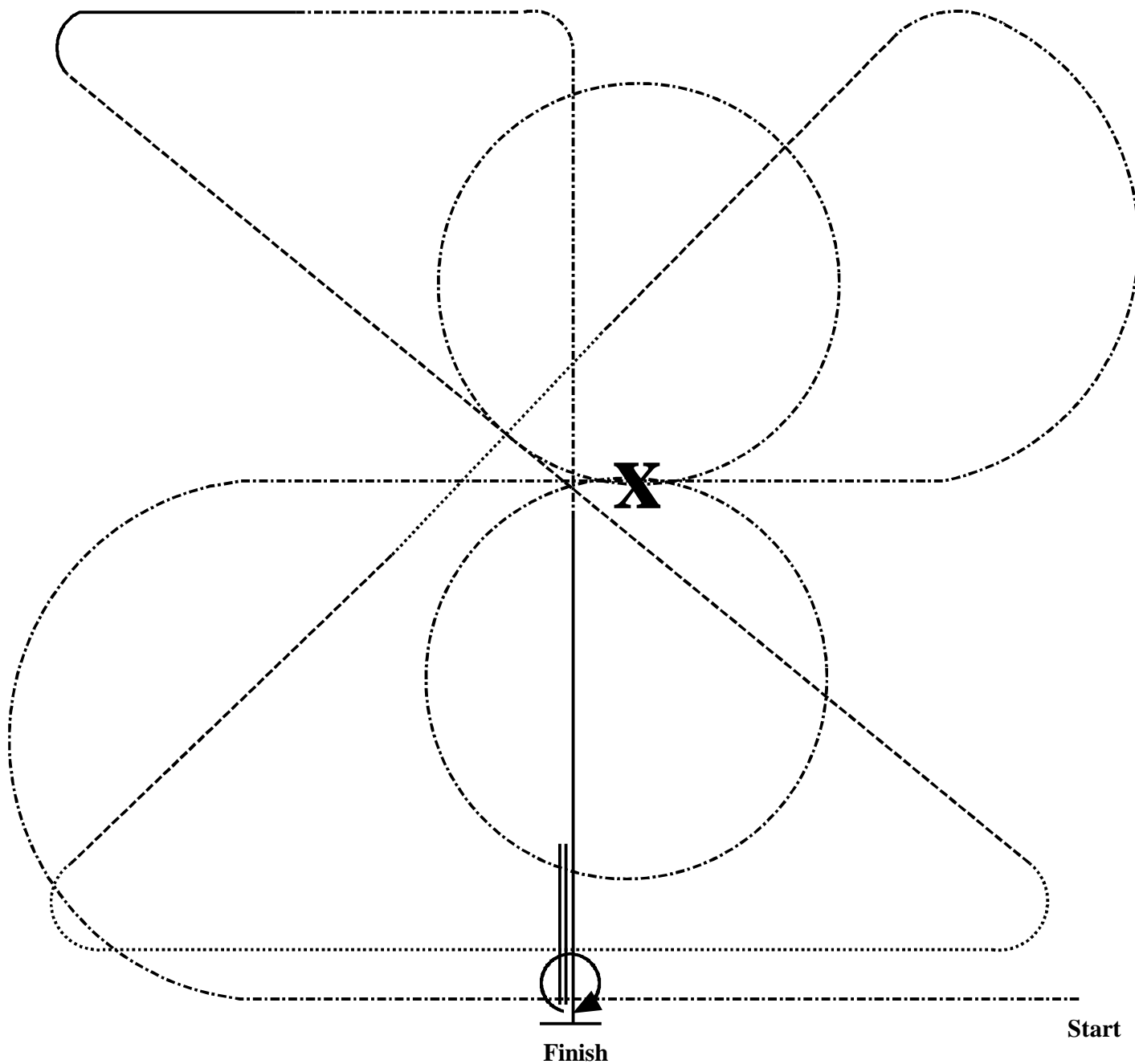

PNWIC
Saddle Seat Equitation #1
 Revised 6.17.14

| Legend: | |
|---------------|-----------|
| Walk | ————— |
| Posting Trot | |
| Extended Trot | - - - - - |
| Canter | - . - . - |
| Back | ===== |

| Date: _____ State: _____ District: _____ | | | |
|--|---|------------------|-------|
| CLASS: <u>SHOWMANSHIP #1</u> | | | |
| HIGH SCHOOL: _____ | | ATHLETE #: _____ | |
| # | ELEMENT JUDGED: | COMMENTS: | SCORE |
| 1. | Start at cone lined up with judge. Pick up trot and then perform circle to right | | |
| 2. | Halt. Perform 360* Left Haunch turn. | | |
| 3. | Perform circle to left on offside and continue straight to judge. | | |
| 4. | Transition to walk; walk to judge (remaining on offside). | | |
| 5. | Set up for inspection. Inspection | | |
| 6. | Back "L" shape to second judge | | |
| 7. | Sidepass 4-6 crossovers to right | | |
| 8. | Perform 630* right haunch turn | | |
| 9. | Trot straight ahead until even with start cone. Halt. Present and wait to be excused. | | |
| 10. | Overall Showmanship | | |
| Judge's Signature: _____ | | | |
| <ul style="list-style-type: none"> • We are looking for the athlete to create a presence that convinces the judge and audience that their horse is the best, and that they have successfully completed every element of the pattern. • Eye contact with the judge, crisp body communication and facial expression are all part of this ground equitation class. • Changes of sides should show the willingness of the horse to yield to the athlete under any conditions. • Condition of coat, feet, mane and tail does count in this class. Handler and horse should be neat, clean, and well groomed • Horse should display no resistance – lead rope and halter should be properly adjusted and appear to not be necessary in the horse's performance. • Handler should not touch the horse to cue for movements. Athletes touching their horse should not expect a zero for that maneuver, but will be marked down. • Correct hand positioning should be used to cue for each maneuver. | | | |

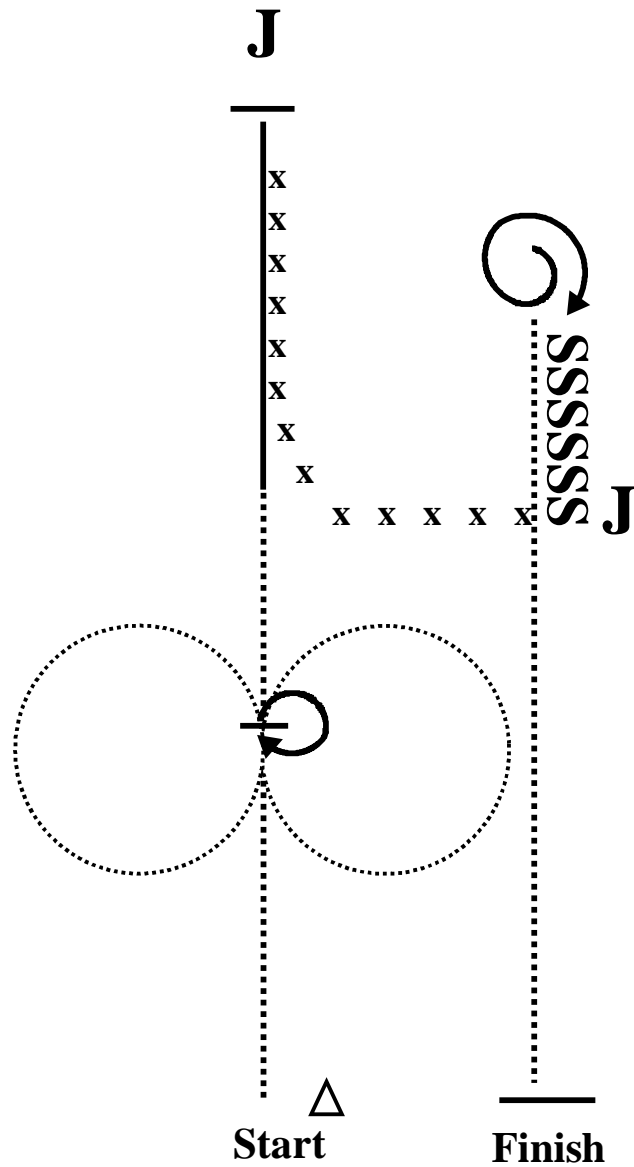

PNWIC
Showmanship #1
 Revised 6.4.14

| Legend: | |
|----------|------------|
| Walk | ————— |
| Jog/Trot | |
| Back | XXXXXXXXXX |
| Sidepass | SSSSSSSSSS |

| Date: _____ State: _____ District: _____ | | | |
|---|---|------------------|-------|
| CLASS: <u>TRAIL #1</u> | | | |
| HIGH SCHOOL: _____ | | ATHLETE #: _____ | |
| # | ELEMENT JUDGED: | COMMENTS: | SCORE |
| 1. | Be ready at cone. Walk into box. Perform 360 tight turn to left (not haunch or forehand). Walk out of box | | |
| 2. | Walk over poles and bridge | | |
| 3. | Transition to left lead lope/canter and continue over poles as diagrammed. | | |
| 4. | Transition to jog/trot; continue through triangle, around cones, and into chute. Halt | | |
| 5. | Back as diagrammed from one side of chute through center to other side of chute | | |
| 6. | Position for Right sidepass. Sidepass Right. | | |
| 7. | Position for left sidepass. Sidepass Left. | | |
| 8. | Pick up jog/trot, and serpentine as diagrammed. Turn into chute and Jog/Trot through chute. | | |
| 9. | Left hand push rope gate. Wait to be excused | | |
| 10. | Overall Horsemanship | | |
| Judge's Signature: _____ | | | |
| Expectations: <ul style="list-style-type: none"> • Horsemanship knowledge in displaying fundamentals is important. Accuracy, smoothness and acceptance of obstacles should be points of training. Timing will count. • Athlete and equine should create a working team. Movement through and over obstacles should be crisp while allowing the equine to negotiate each step. • Leads should be accurate and backing should be precise, but not too slow. • Haunch turns, pivots, lateral movements and backing should be smooth with continual movement. • Refusals will deduct points. After 2 unsuccessful attempts, riders will be asked to move on. A refusal is any unnecessary and unintentional movement not aiding in completion of the maneuver. The following two examples would be considered refusals. A horse taking a step backwards while approaching a bridge without being asked to do so by its rider. A horse taking a step forward while attempting to complete a back through without being asked to do so by its rider. An unintentional complete stop of movement while approaching or completing an obstacle will also be considered a refusal. • Judges will be looking for a "finished" equine/athlete combination in this event. | | | |

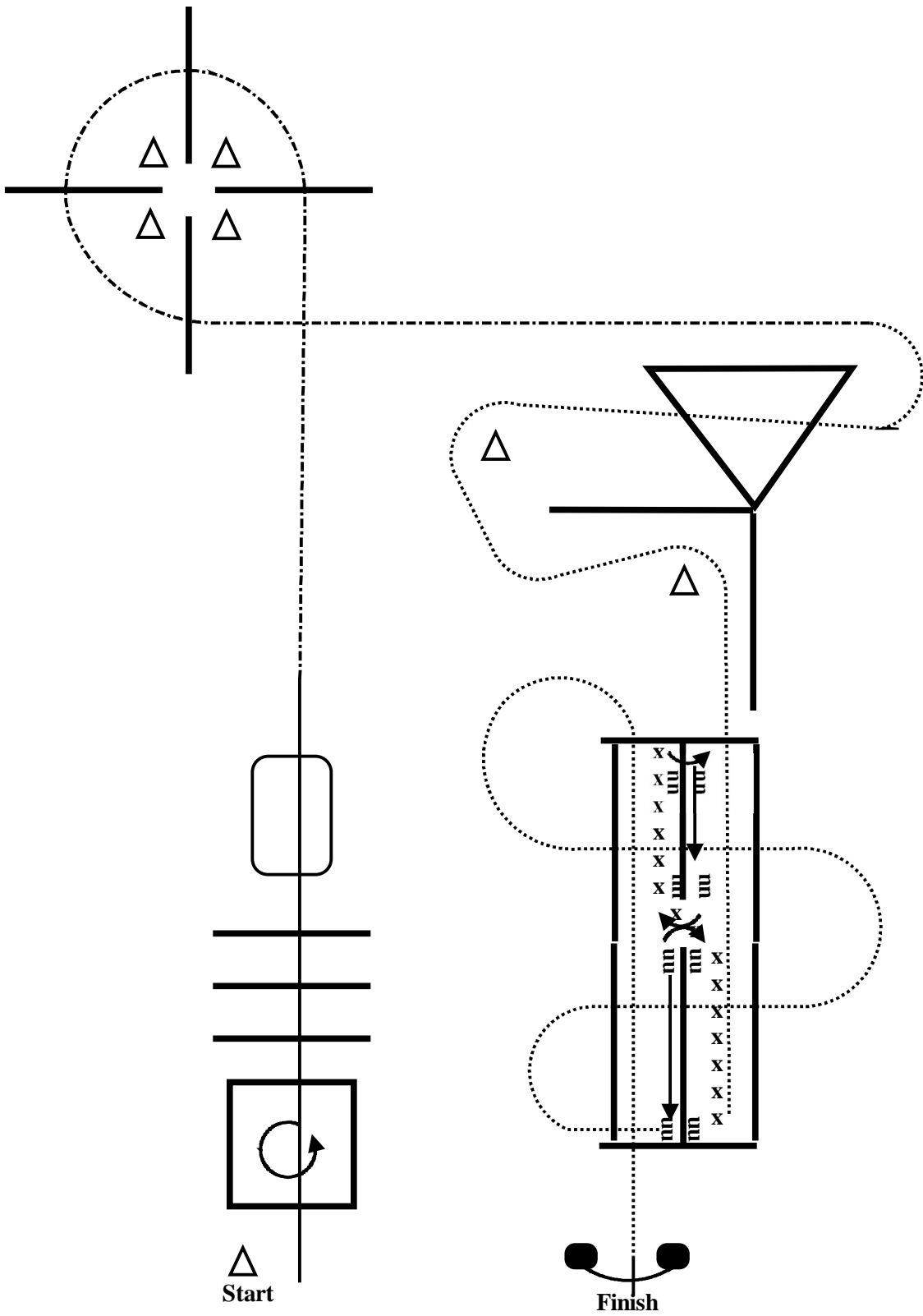

PNWIC
Trail #1
 Revised 5.21.14

| Legend: | |
|--------------------|------------|
| Walk | ————— |
| Jog/Trot | |
| Lope/Canter | - - - - - |
| Back | XXXXXXXXXX |

Begin by placing left standard of rope gate. Needs to be 85-90' from opposite wall and 56' from left wall. Should be at least 25' from right wall. Set gate.
 Measure 10' from left standard to set chute. Build outer wall of chute. When tape is stretched across width of chute lace 8' poles on 3'. Next build poles off of triangle.
 Cones on lope poles should be placed one foot from end of pole.
 After completing lope poles measure down for walkovers first, then measure and set bridge from walkover poles.

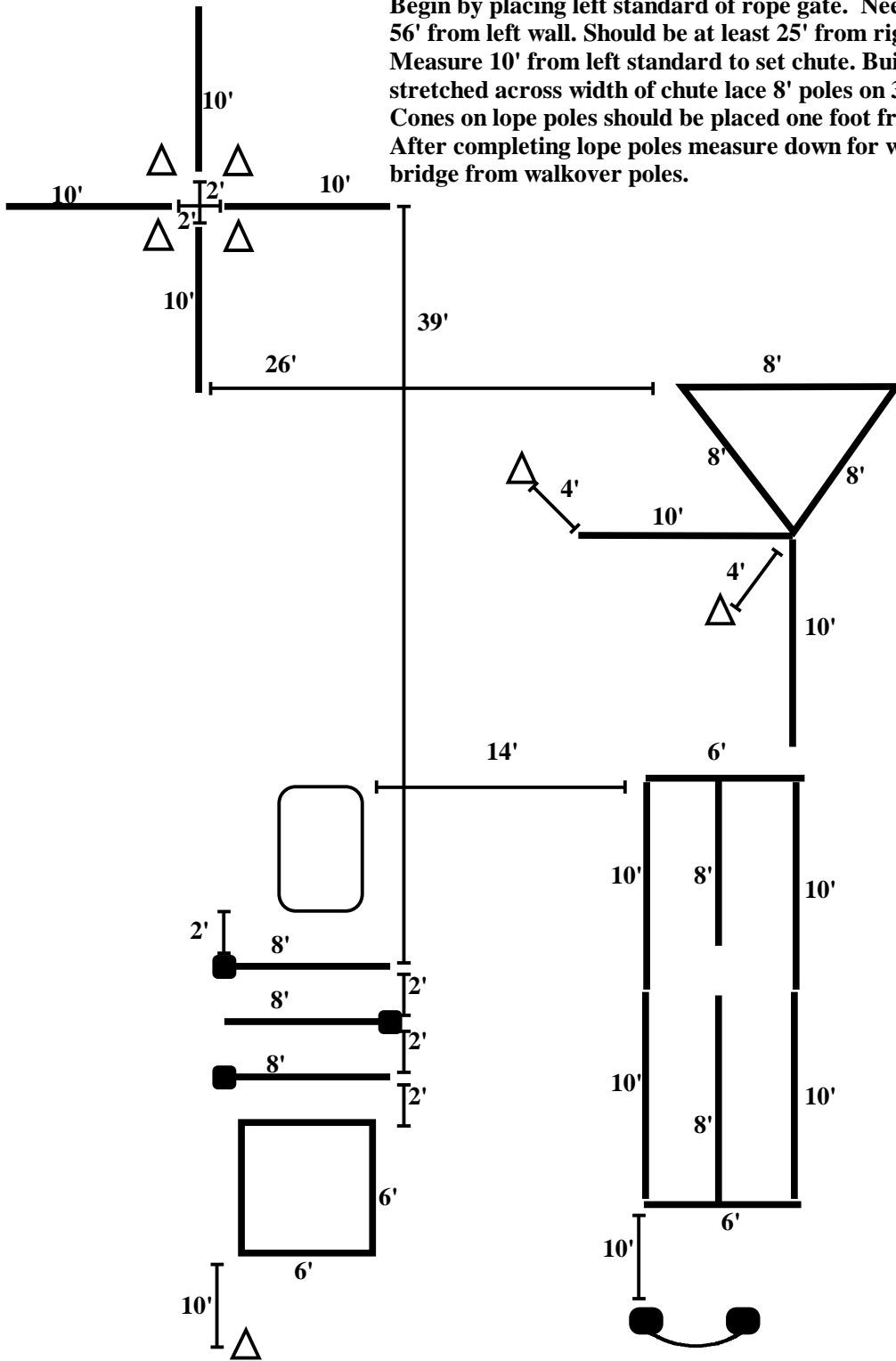

| Equipment Needed: |
|---|
| (10) 10' poles |
| (8) 8' poles |
| (6) 6' poles |
| (7) Standard size cones (about 18" tall) |
| Bridge (min 4' x 6') |
| Rope gate (2 jump standards with rope. Min 4 wide) |
| (3) Risers for walk over poles. (top of pole should be 8"-12" high) |

PNWIC In
Trail #1
 Revised 5.29.14

| Date: _____ | | State: _____ District: _____ | |
|---|--|------------------------------|-------|
| CLASS: <u>Western Horsemanship #1</u> | | | |
| HIGH SCHOOL: _____ | | ATHLETE #: _____ | |
| # | ELEMENT JUDGED: | COMMENTS: | SCORE |
| 1. | Be ready on diagonal WITHOUT FEET IN STIRRUPS. Pick up jog. | | |
| 2. | Extend jog and circle left | | |
| 3. | Transition to LEFT lead lope and circle right (counter canter) | | |
| 4. | Change leads. | | |
| 5. | Before corner put feet in stirrups, turn right and continue lope. Turn right onto long wall, and then right into center. | | |
| 6. | Change Leads | | |
| 7. | In center increase energy of lope and turn then turn left onto long wall, and then left toward short wall. | | |
| 8. | In center of short wall transition to walk. Halt | | |
| 9. | 450* right haunch turn. Back 6 steps or so | | |
| 10. | Wait for judge to excuse you then jog toward exit of arena | | |
| 11. | Overall Horsemanship | | |
| 12. | Rider Equitation: Seat, Hands, Legs | | |
| Judge's Signature: _____ | | | |
| <ul style="list-style-type: none"> • Equitation skills in performing smooth elegant maneuvers and transitions score higher. Understanding what the pattern calls for and planning arena space will enhance the performance. There should be a definite distinction in stride length between the jog, and the extended jog. • This pattern is asking for the athletes' <u>BEST</u> lead changes. The following is the general guideline for scoring lead changes (the scores are maximum possible if every part of the element including the lead change is perfect): <ul style="list-style-type: none"> Flying Lead Change – maximum possible 10 Interrupted Lead Change – maximum possible 8 Simple Lead Change – maximum possible 6 • Clearly, the goal is a perfect flying lead change, however, this allows for athletes to work into this maneuver. Remember, perfect means: equitation, hands, change (no steps in an interrupted, few steps in simple, no disunited steps in flying and so on.) • This is an equitation class. Body position of athlete is scored; behavior of the equine is the direct result of the athlete's horsemanship skills. | | | |

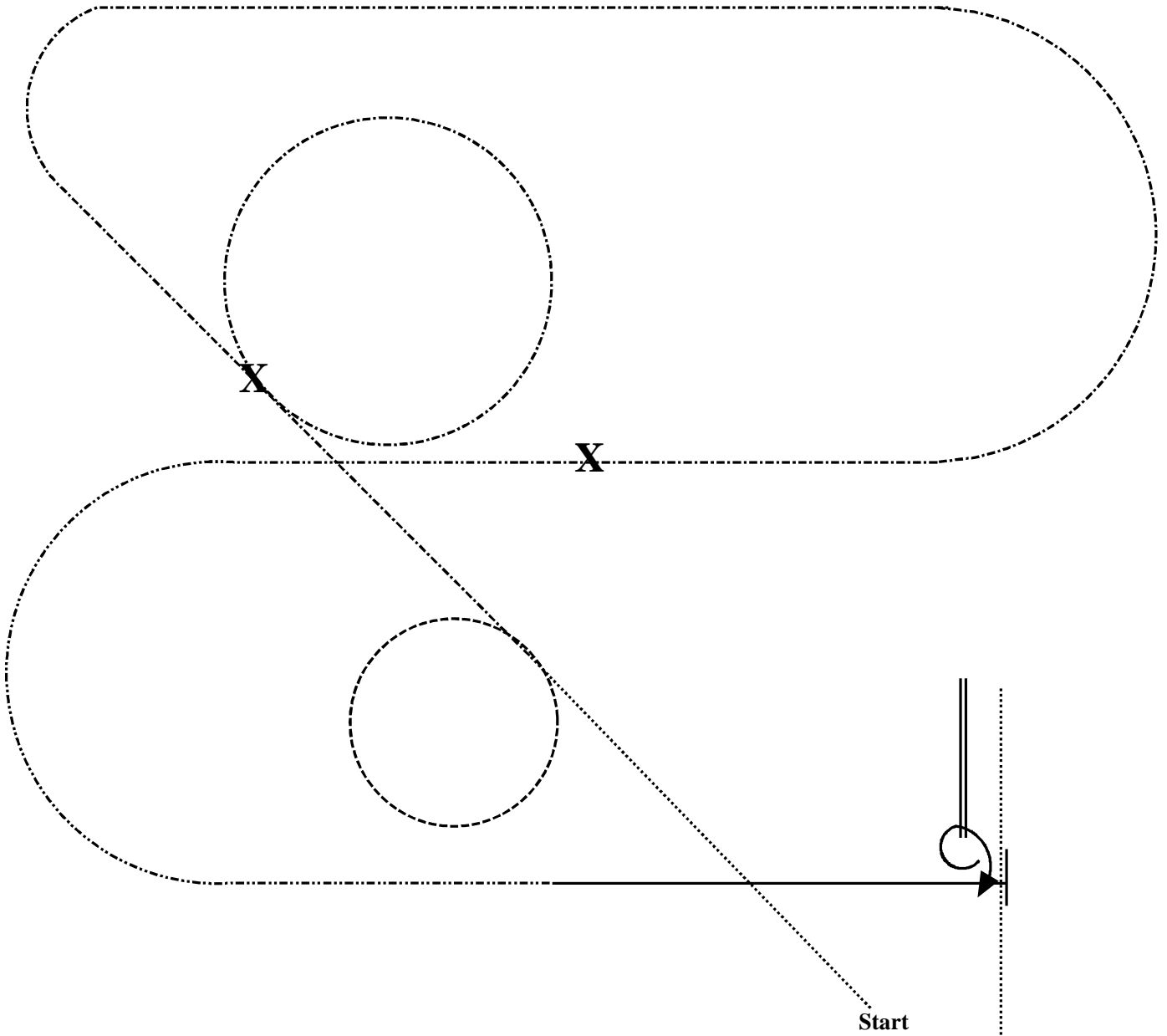

Start

Finish

PNWIC
 Western Horsemanship #1
 Revised 5.29.14

| Legend: | |
|--------------------------|-----------|
| Walk | ————— |
| Jog | |
| Extended Jog | - - - - - |
| Lope | - · - · - |
| Lope w/ Increased Energy | - · - · - |
| Back | ===== |

Date: _____ State: _____ District: _____
CLASS: WORKING PAIRS #1

HIGH SCHOOL: _____ ATHLETE #: _____

| # | ELEMENT JUDGED: | COMMENTS: | SCORE |
|-----|---|-----------|-------|
| 1. | Be ready at A. Pick up jog and each rider performs two circles to away from partner simultaneously | | |
| 2. | At C riders split and head toward H and M, then turning onto diagonal line. Each rider two tracks toward partner meeting before reaching A. | | |
| 3. | At A riders halt and perform 180* haunch turn. Rider 1 (red) turns right; Rider 2 (blue) turns left. | | |
| 4. | Rider 1 (red) picks up right lead and positions to begin circle to right. Rider 2 (blue) picks up left lead and positions to begin circle to left | | |
| 5. | Rider 1 (red) completes 1 full circle beginning at C to right. Rider 2 (blue) completes 1 full circle beginning at C to left. | | |
| 6. | At C riders transition to extended jog/trot. Rider 1 (red) C, M, X, K, A. Rider 2 (blue) C, H, X, F, A. | | |
| 7. | Riders meet at A, transition to lope/canter and continue straight up center to A. Halt, Salute. 90* Haunch turn. Rider 1 Left, Rider 2 Right. | | |
| 8. | Transition to jog/trot and begin serpentine/lace the boot maneuver. Riders should change lead for each cross. Rider 1 should cross first in first cross, and then rider 2 should cross first for 2 nd cross etc. | | |
| 9. | Riders should meet, cross and roll back before A, then jog/trot out of arena. | | |
| 10. | Overall Horsemanship | | |
| 11) | Degree of Difficulty | | |

Judge's Signature: _____

*This class is judged on individual horsemanship skills, which include correct leads, balanced gaits, transitions and overall uniformity. Smooth and quiet use of aids to maintain conformity is essential.
 *Mirror images are important. Circles should be round and equal.
 *Work for simultaneous lope/canter departs and haunch turns.
 *Timing is an essential part of this class. Use of the arena and timing of transitions will be evaluated for score.
 *The pattern should be smooth and the music and decoration on the equines should not distract from the overall performance. If music is offensive to judge or general audience it should be noted in the Overall Horsemanship score.
 *All maneuvers should be in unison. And riders should stay "Shoulder to Shoulder"
 *Degree of difficulty score will be based on what type of bridle and equipment are used to maneuver horse. For example, two hands on a curb will be given a lower degree of difficulty score than riders using one hand.
 *Any bit may be used in this class, and reins may be held by any safe method.
 *In element #1 riders should be on opposite leads. They should pick up the correct lead for their direction of circle

Equipment Needs: All Small Dressage arena letters (A, K, E, H, C, M, B, F)

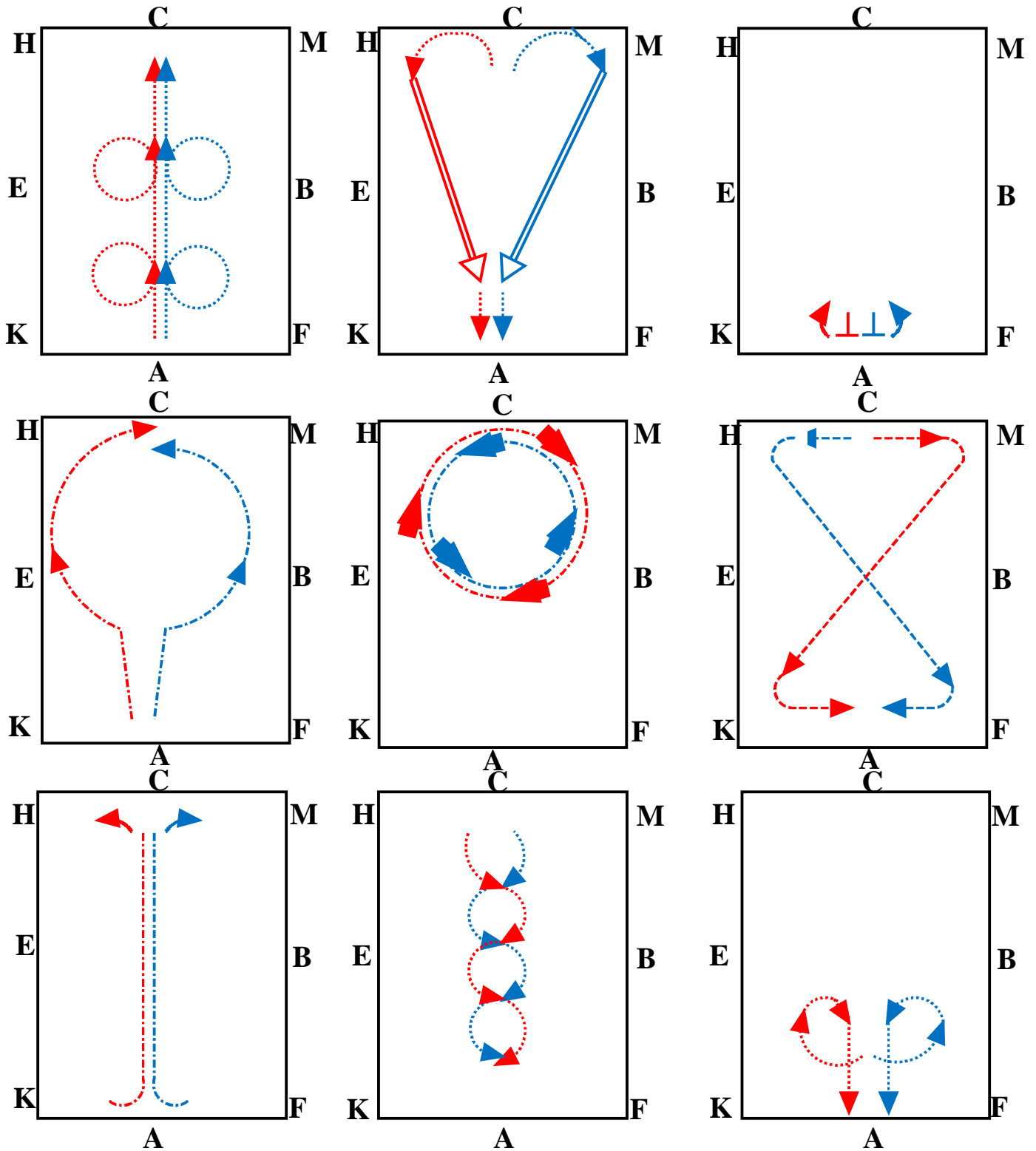

Note: Rider 2 is Blue, Rider 1 is Red

PNWIC
Working Pairs #1

Revised 5.21.14

| Legend: | |
|-------------------|-----------|
| Walk | ————— |
| Jog/Trot | |
| Extended Jog/Trot | - - - - - |
| Lope/Canter | - · - · - |
| Two Track | ===== |
| Back | XXXXXXXXX |

Date: _____

State: _____

District: _____

CLASS: WORKING RANCHER PATTERN #4

HIGH SCHOOL: _____

ATHLETE #: _____

| # | ELEMENT JUDGED: | COMMENTS: | Score |
|-----|---|-----------|-------|
| 1. | Wait at cone with loop built, extend trot between poles | | |
| 2. | Between barrels pick up lope with energy around cone | | |
| 3. | Switch leads at center between barrels, collect lope, continue as diagramed | | |
| 4. | While in motion throw rope, halt, dally, drop rope | | |
| 5. | Walk to barrel, pick up saddle bags, jog to second barrel | | |
| 6. | Place saddle bags on second barrel, jog to pen | | |
| 7. | Open gate, right hand push | | |
| 8. | Push cow to and hold behind wall | | |
| 9. | Exit pen, left hand push | | |
| 10. | Jog over poles, walk over bridge and pole | | |
| 11. | 360° left haunch turn | | |
| 12. | Dismount and lead out of arena | | |
| 12. | Overall Horsemanship. | | |

Judge's Signature: _____

Expectations:

- This class should show the horse's ability to work at a forward, working pace while under control by the rider. There should be time for the equine to negotiate each obstacle just as on the ranch, but there should be no refusals or hesitation when asked to perform any task.
- Allowed one attempt at roping calf head. Athlete should show they can handle a rope smoothly and efficiently.
- Rider aids should be used quietly and unobserved, completing one element and getting ready to execute the next without undue jerking and pulling on the equine.
- This pattern is designed to show the athlete's expertise in the proper use of ropes, keeping the equine under control and completing the ranch job with the least amount of energy involved. Excess use of bit and reins should be avoided and noted in the score.
- Though this pattern should be ridden with more speed and purpose than trail, the athlete should have a willing and relaxed equine at all times.
- Athletes may use two hands with a snaffle or bosal bits only.
- The maximum time allowed for cattle movement is 60 seconds.
- Bit checks are at the discretion of the judge.

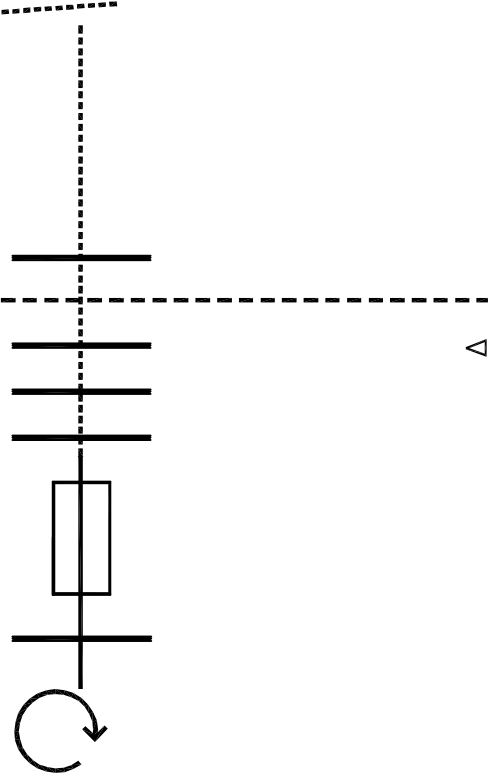
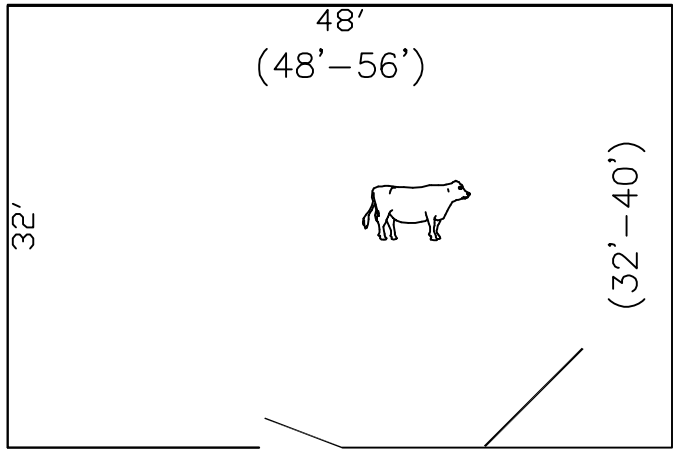
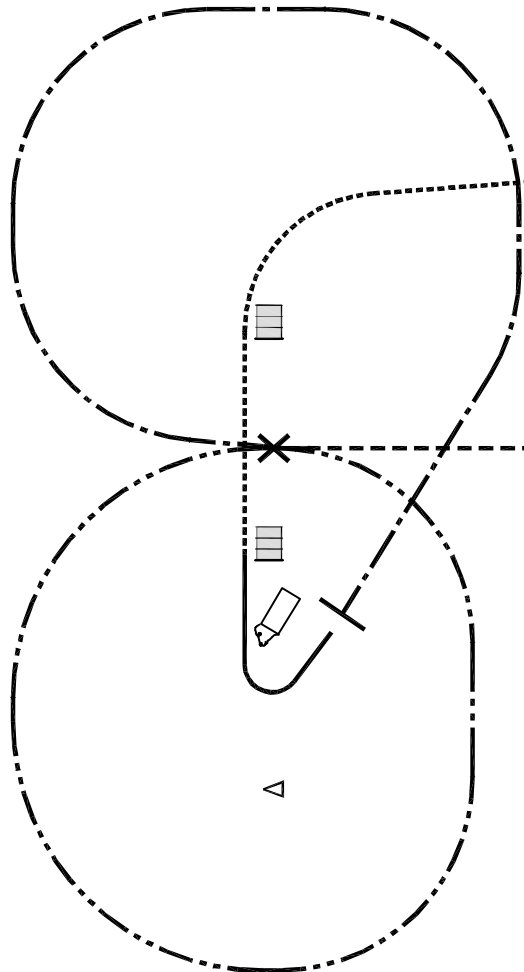

PNWIC
#4
Working Rancher
 Revised 4-26-2026

| Legend : | |
|----------------|-----------|
| Walk | ————— |
| Jog | - - - - - |
| Extended Jog | - - - - - |
| Lope | — · — · — |
| Lope w/ Energy | - - - - - |
| Back | X X X X X |
| Start Cone | △ |

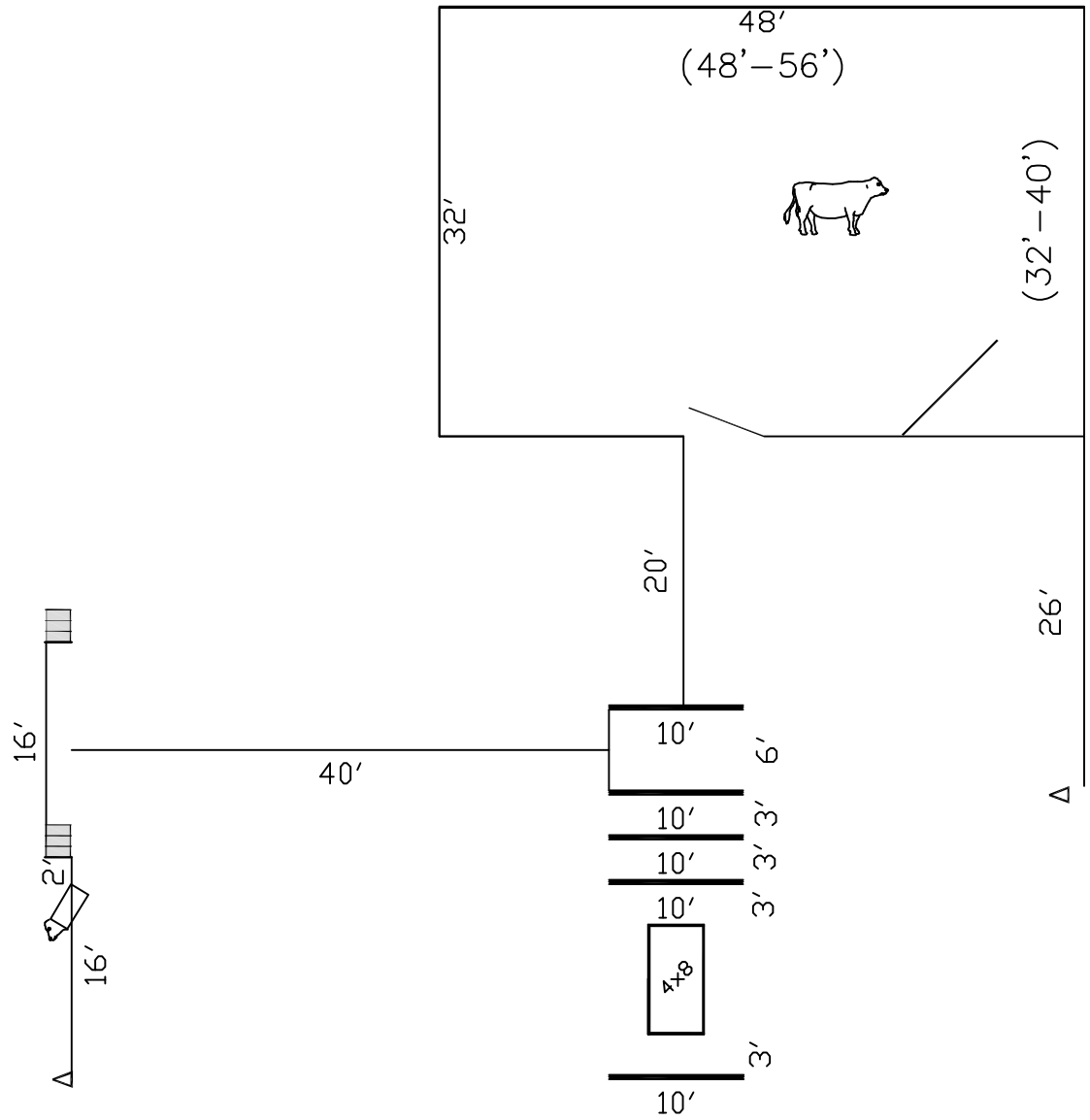

PNWIC
#4
Working Rancher

Revised 4-26-2026

| Equipment List: |
|---|
| (2) Barrels |
| (5) 10' poles, maximum 4" diameter |
| (1) 4'x8' bridge |
| (1) Saddle bags |
| (1) Straw bale |
| (1) Calf head |
| (2) Standard cones |
| (2) Calves (1 to be used at a time, change every 10 athletes) |